

Fasteners





UES
international



Over Centre Fasteners 71 Series

OF71LZP, OF71LSS

MATERIAL

OF71LZP - Cold Rolled Steel
 OF71LSS - 316 Stainless Steel

FINISH

OF71LZP - Zinc Plated
 OF71LSS - Electropolished

WEIGHT

41g

FEATURES

Padlockable
 Suits Strikers OF71HKZP-1 & OF71HKSS-1

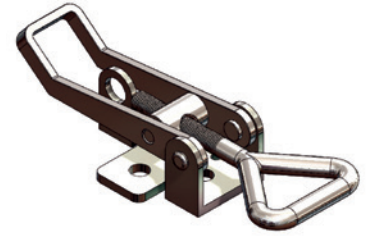
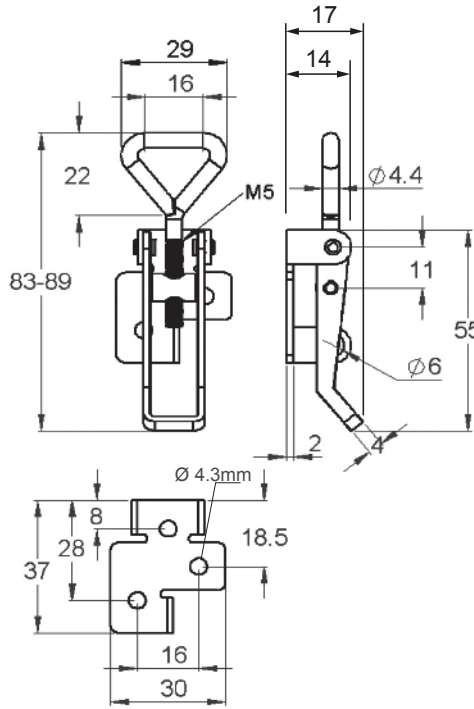

Over Centre Fasteners with Safety Catch 71 Series

OF71LCZP

MATERIAL

Cold Rolled Steel

FINISH

Zinc Plated

WEIGHT

41g

FEATURES

Padlockable
 With Safety Catch & Nylon Bushing
 Suits Strikers OF71HKZP-3 & OF71HKZP-1

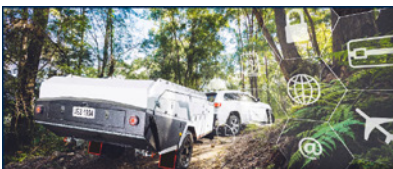
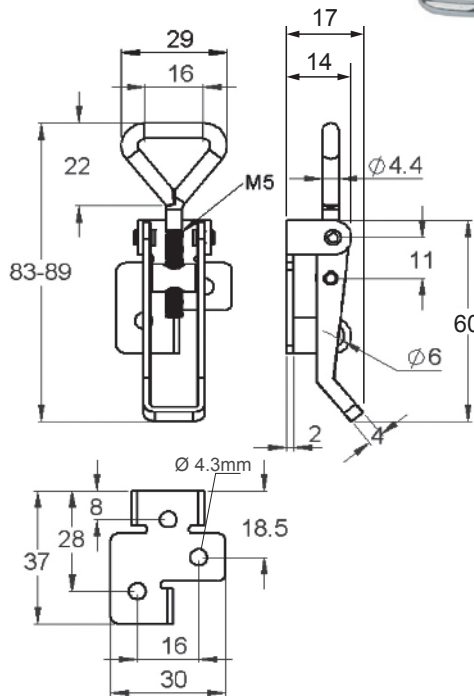

Over Centre Fasteners 71 Series

OF71NLZP, OF71NLSS

MATERIAL

OF71NLZP - Cold Rolled Steel
 OF71NLSS - 316 Stainless Steel

FINISH

OF71NLZP - Zinc Plated
 OF71NLSS - Electropolished

WEIGHT

36g

FEATURES

Suits Strikers OF71HKZP-1 & OF71HKSS-1

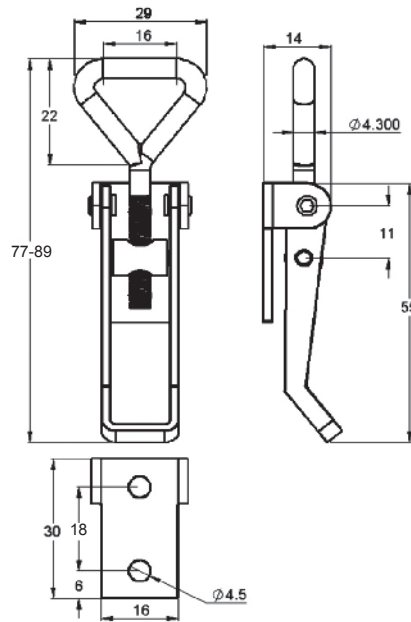

Over Centre Fasteners 72 Series

OF72LZP, OF72LSS

MATERIAL

OF72LZP - Cold Rolled Steel
 OF72LSS - 316 Stainless Steel

FINISH

OF72LZP - Zinc Plated
 OF72LSS - Electropolished

WEIGHT

80g

FEATURES

Padlockable
 Suits Strikers OF72KHZP-1 & OF72HKSS-1
 OF71HKZP-3 & OF71HKSS-3

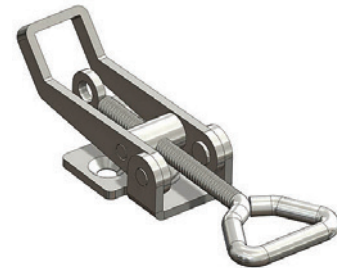
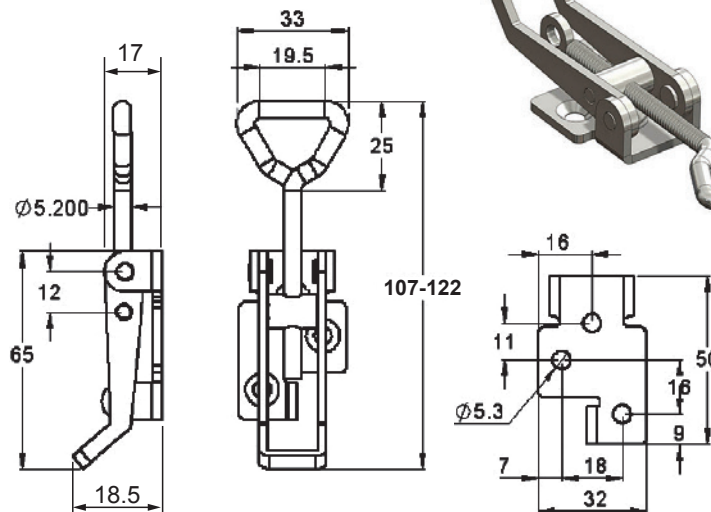

Over Centre Fasteners 72 Series

OF72NLZP, OF72NLSS

MATERIAL

OF72NLZP - Cold Rolled Steel
 OF72NLSS - 316 Stainless Steel

FINISH

OF72NLZP - Zinc Plated
 OF72NLSS - Electropolished

WEIGHT

72g

FEATURES

Suits Strikers OF72KHZP-1 & OF72HKSS-1
 OF71HKZP-3 & OF71HKSS-3

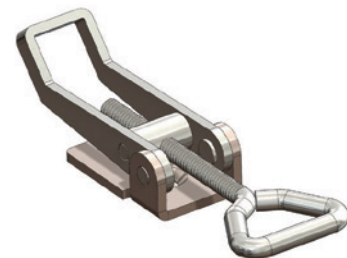
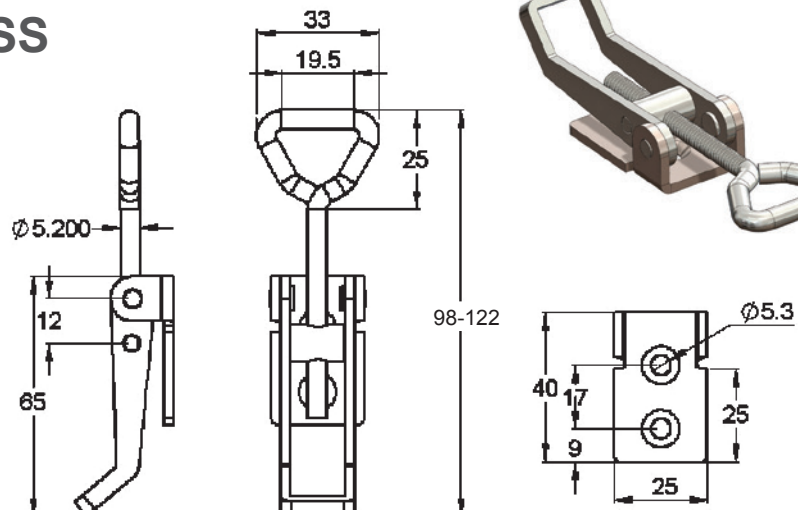

Over Centre Fasteners 72 Series OF72NLZP-WB, OF72NLSS-WB

MATERIAL

OF72NLZP-WB - Cold Rolled Steel
OF72NLSS-WB - 316 Stainless Steel

FINISH

OF72NLZP-WB - Zinc Plated
OF72NLSS-WB - Raw

WEIGHT

84g

FEATURES

Suits Strikers OF71HKZP-3, OF72KHZP-1
OF71HKSS-3, OF72HKSS-1

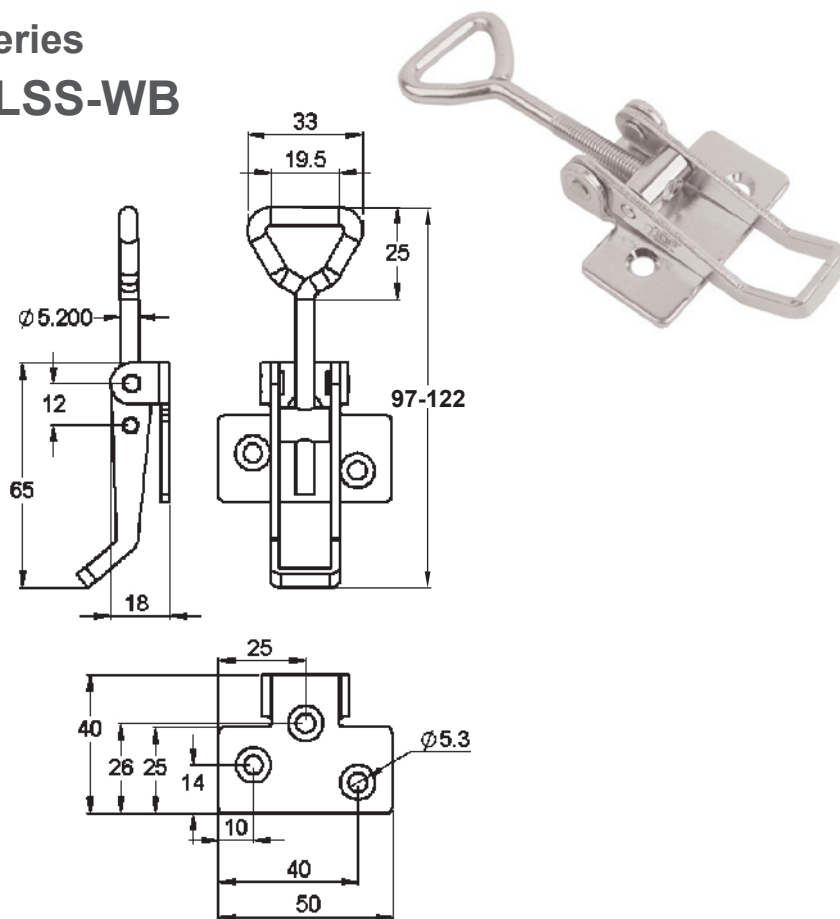

Over Centre Fastener with Safety Catch 72 Series OF72LCZP, OF72LCSS

MATERIAL

OF72LCZP: Mild Steel
OF72LCSS: 316 Stainless Steel

FINISH

OF72LCZP: Zinc Plated
OF72LCSS: Electropolished

FEATURES

OF72LCZP:
Suits Strikers OF71HKZP-3, OF72KHZP-1
OF72LCSS:
Suits Strikers OF71HKSS-3, OF72HKSS-1
With Safety catch
Nylon bushing

WEIGHT

94g

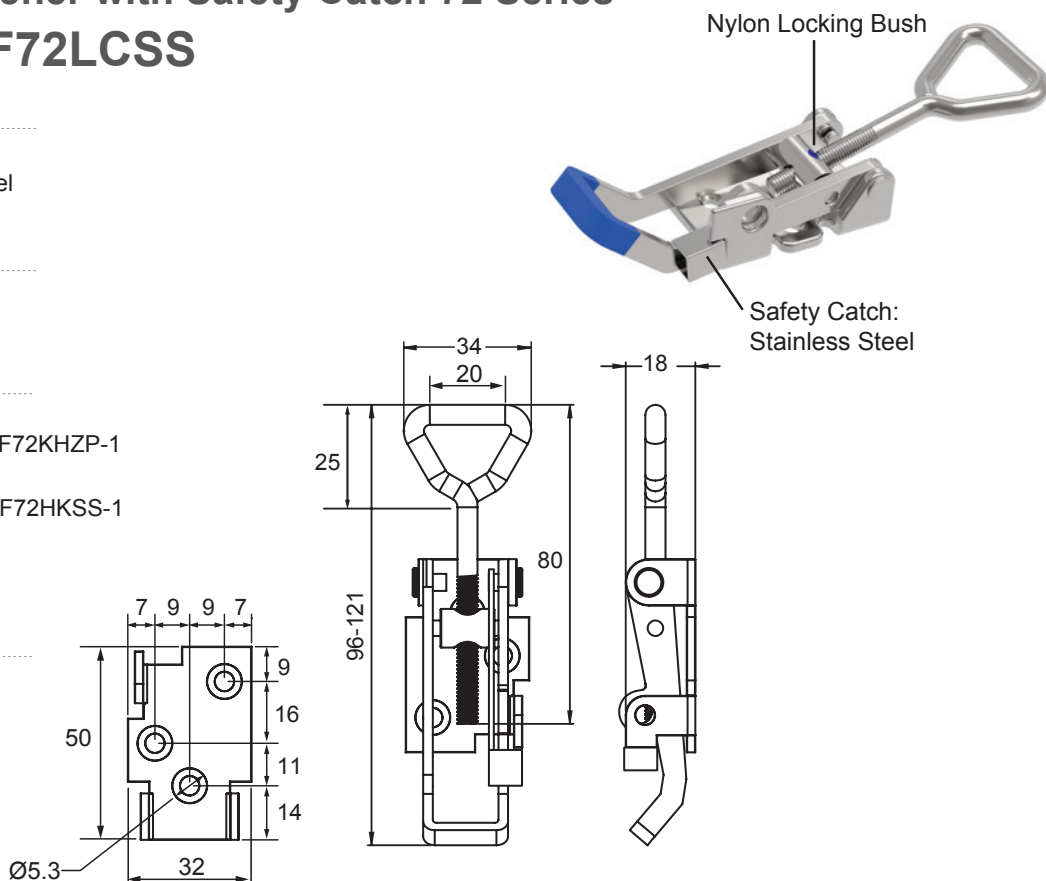

Over Centre Fasteners with Safety Catch 73 Series

OF73LCZP

MATERIAL

Cold Rolled Steel

FINISH

Zinc Plated

WEIGHT

230g

FEATURES

S/S Safety Catch

Padlockable

Nylon Locking Bush

Suits Strikers OF73HKZP-1
and OF73HKZP-2

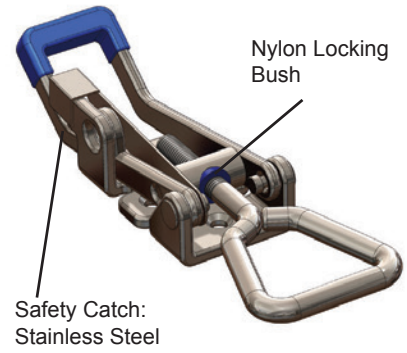
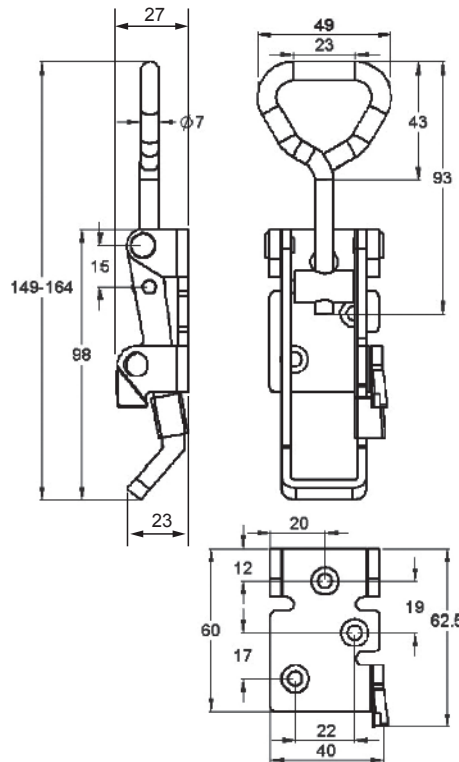

Over Centre Fasteners 73 Series

OF73LZP, OF73LSS

MATERIAL

OF73LZP - Cold Rolled Steel

OF73LSS - 316 Stainless Steel

FINISH

OF73LZP: Zinc Plated

OF73LSS: Electropolished

WEIGHT

200g

FEATURES

Padlockable

OF73LZP: Suits Strikers
OF73HKZP-3, OF73HKZP-2, OF73HKZP-1

OF73LSS: Suits Strikers
OF73HKSS-3, OF73HKSS-2, OF73HKSS-1

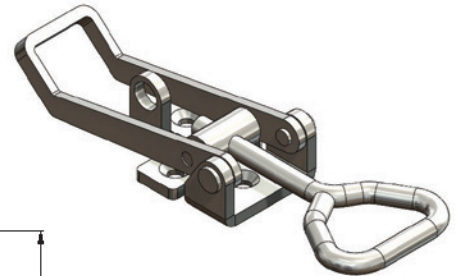
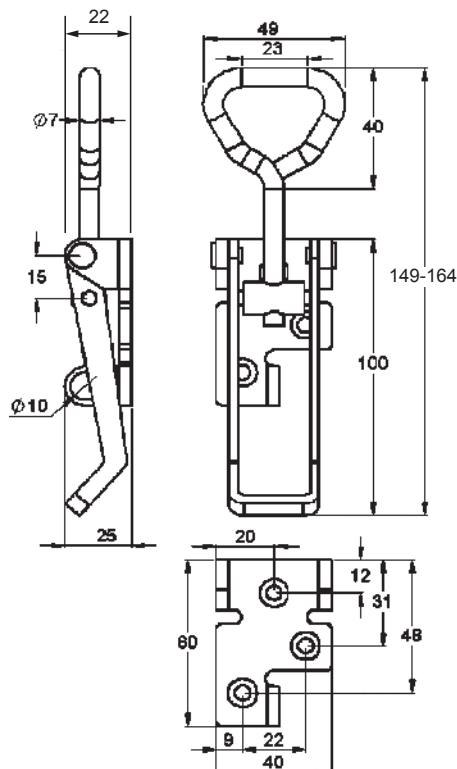

Over Centre Fasteners 73 Series OF73LZP-4

MATERIAL

Cold Rolled Steel

FINISH

Zinc Plated and Stainless Steel available
(Electrolytic Brightening)

WEIGHT

188g

FEATURES

Padlockable

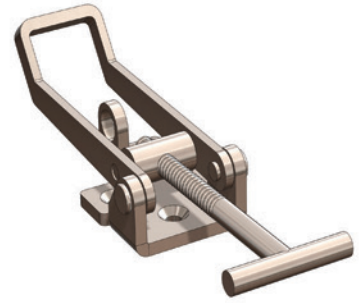
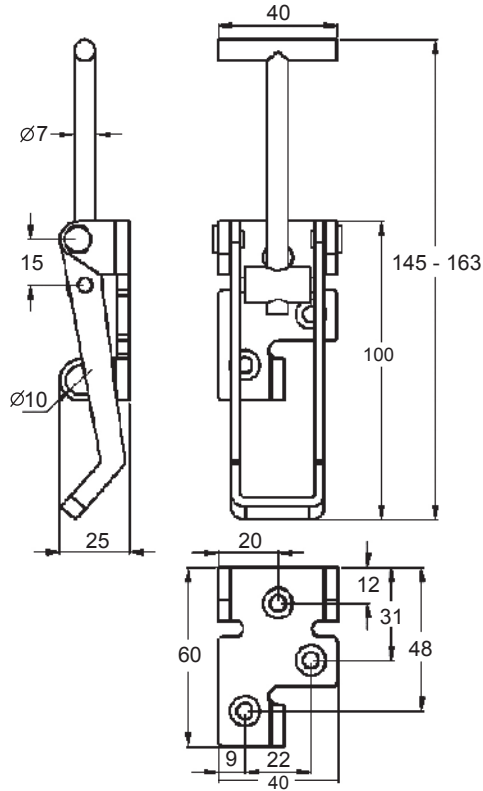

Over Centre Fasteners 84 Series OF84LCZP

MATERIAL

Hot Rolled Steel

FINISH

Zinc Plated

WEIGHT

912g

FEATURES

Suits Striker OF84HKZP-4

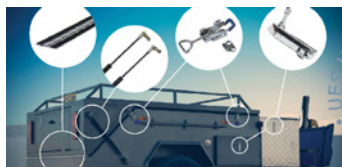
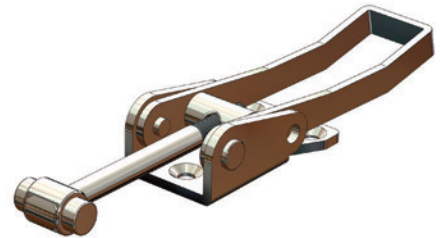
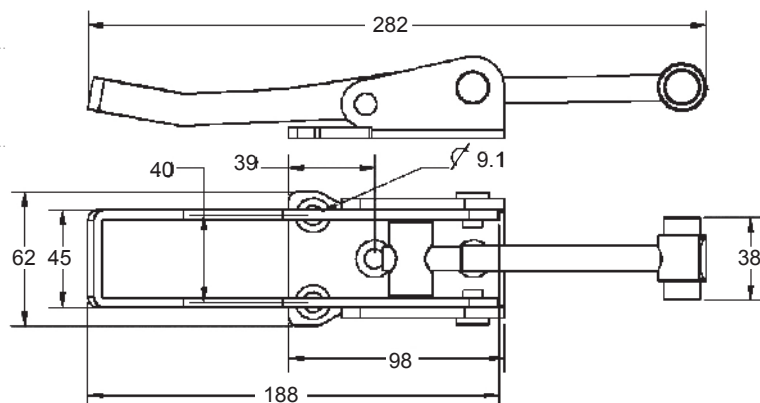

UES Trade Card

5% off our entire range,
plus access to special discounts & giveaways
Visit us on www.uesint.com

UES
international
Trade Card

Member N° 00000 Engineering Solutions Provider

Over Centre Fastener - Hook Plate OF73HKZP-2, OF73HKSS-2

MATERIAL

OF73HKZP-2: Cold Rolled Steel
OF73HKSS-2: Stainless Steel

FINISH

OF73HKZP-2: Zinc Plated
OF73HKSS-2: Electropolished

WEIGHT

78g

FEATURES

Suits 73 Series

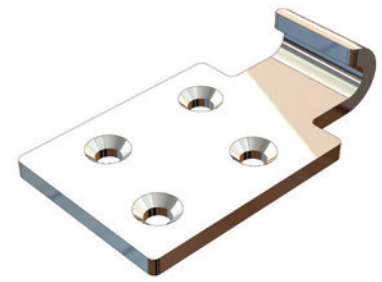
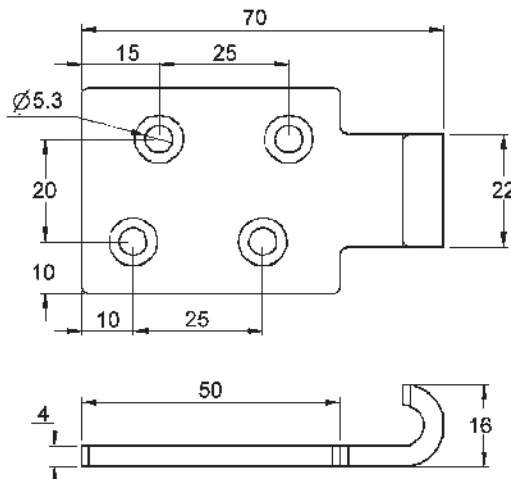

Over Centre Fastener - Hook Plate OF71HKZP-1, OF71HKSS-1

MATERIAL

OF71HKZP-1: Cold Rolled Steel
OF71HKSS-1: Stainless Steel 316

FINISH

OF71HKZP-1: Zinc Plating
OF71HKSS-1: Electropolished

WEIGHT

7g

FEATURES

Suits 71 Series

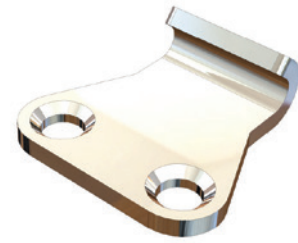
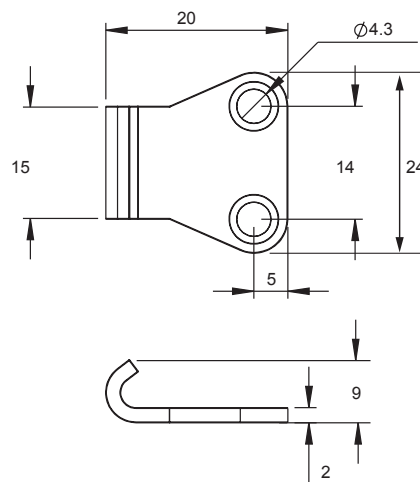

Over Centre Fastener - Hook Plate OF72HKZP-1, OF72HKSS-1

MATERIAL

OF72HKZP-1: Cold Rolled Steel
OF72HKSS-1: Stainless Steel 316

FINISH

OF72HKZP-1: Zinc Plated
OF72HKSS-1: Electropolished

WEIGHT

13g

FEATURES

Suits 72 Series

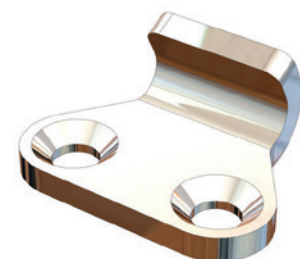
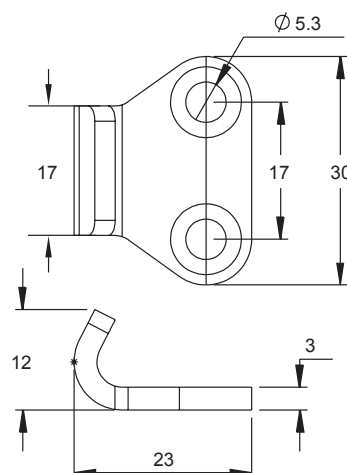

Over Centre Fastener - Hook Plate OF73HKZP-1, OF73HKSS-1

MATERIAL

OF73HKZP-1: Cold Rolled Steel
OF73HKSS-1: Stainless steel 316

FINISH

OF73HKZP-1: Zinc plated
OF73HKSS-1: Electropolished

WEIGHT

33g

FEATURES

Suits 73 Series

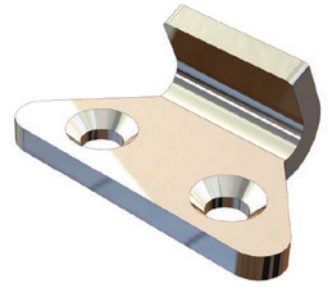
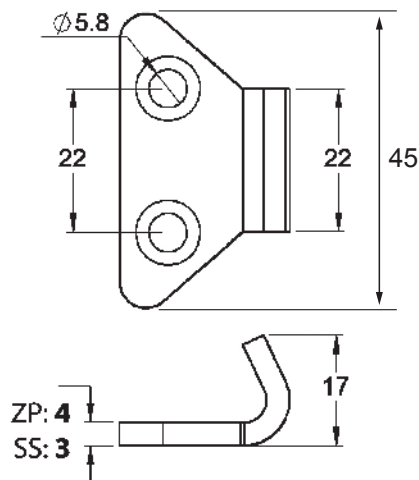

Over Centre Fastener - Catch Plate OF84HKZP-4

MATERIAL

Hot Rolled Steel

FINISH

Zinc Plated

WEIGHT

912g

FEATURE

Use with Latch OF84LCZP

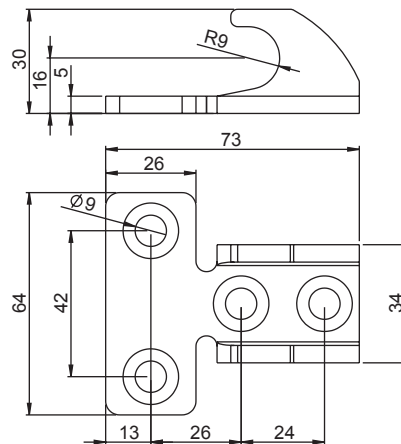

Over Centre Fastener - Hook Plate OF72HKZP-2

MATERIAL

Cold Rolled Steel

FINISH

Zinc Plated

WEIGHT

17g

FEATURES

Suits 72 Series

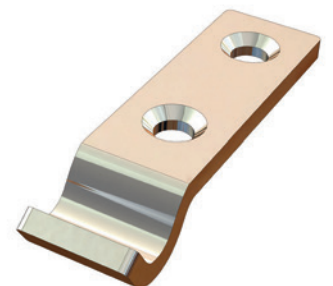
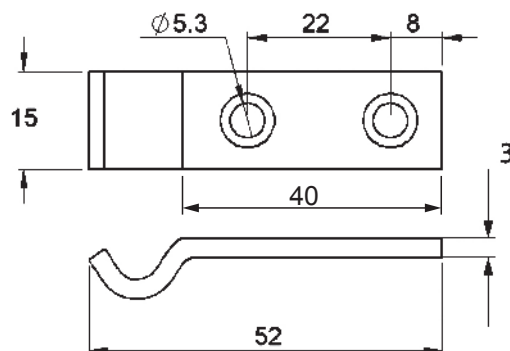

Over Centre Fastener - Hook Plate

OF71HKZP-3, OF71HKSS-3

MATERIAL

OF71HKZP-3: Cold Rolled Steel
 OF71HKSS-3: Stainless Steel

FINISH

OF71HKZP-3: Zinc Plated
 OF71HKSS-3: Electropolished

WEIGHT

32g

FEATURES

Suits 71 Series

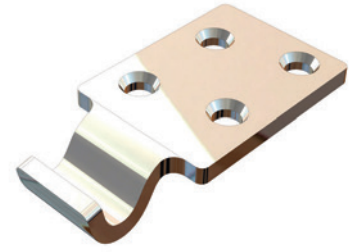
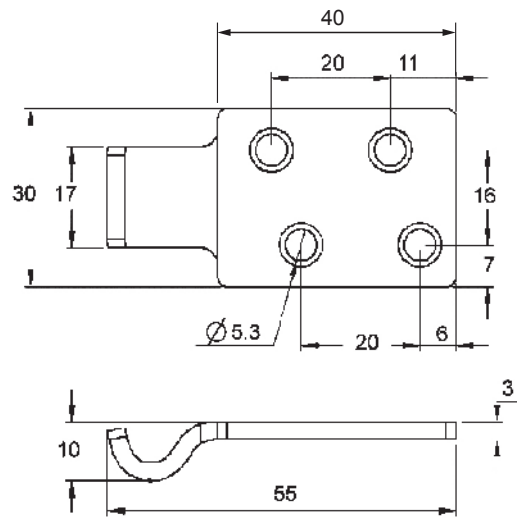

Over Centre Fastener - Hook Plate

OF73HKZP-3, OF73HKSS-3

MATERIAL

OF73HKZP-3: Cold Rolled Steel
 OF73HKSS-3: Stainless Steel

FINISH

OF73HKZP-3: Zinc Plated
 OF73HKSS-3: Electropolished

WEIGHT

76g

FEATURES

Suits 73 Series

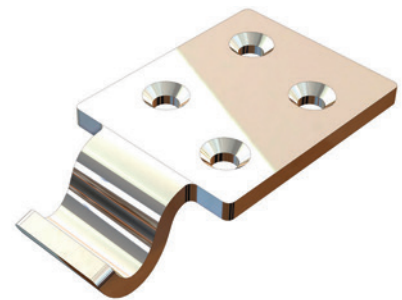
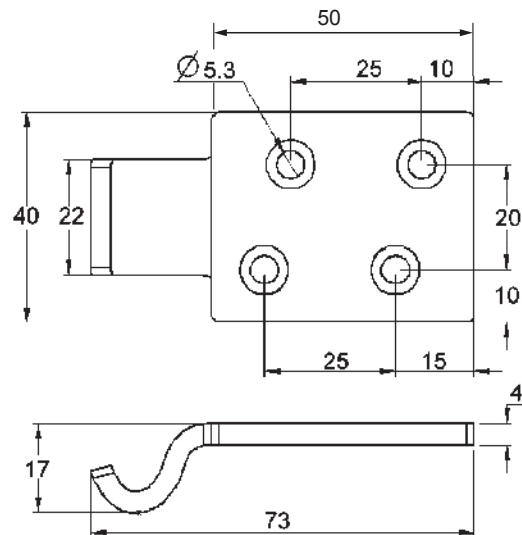

**Water Tanks
 Specials**

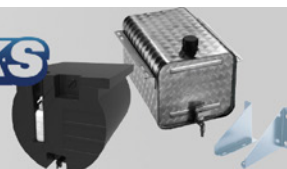

**Call us
 1300 00 1904
 for further information**

Draw Latch - Lockable OF1040SS

MATERIAL

304 Stainless Steel

FINISH

Polished

WEIGHT

105g

FEATURES

Lift handle and turn 180 degrees open and close latch.
Stainless draw latch with key.

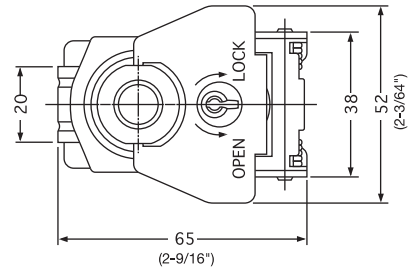
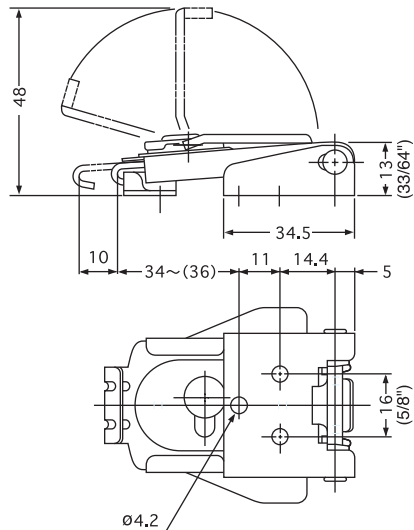

Tray Body Over Centre Fastener with Hook OF5258ZP, OF5258SS

MATERIAL

OF5258ZP - Steel

OF5258SS - 304 Stainless Steel

FINISH

OF5258ZP - ZP

OF5258SS - Polished

WEIGHT

480g

FEATURES

Adjustable

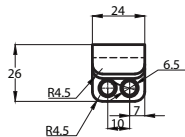
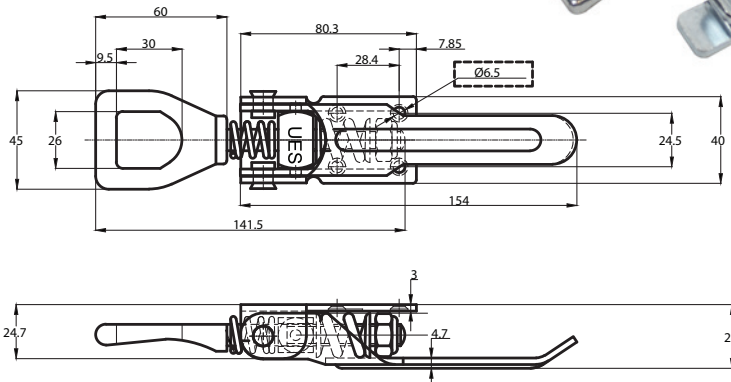

Over Centre Fastener w/ Catch Plate OF5ZP

MATERIAL

Steel

FINISH

ZP

WEIGHT

406g

FEATURES

Thread = 3/8" BSW

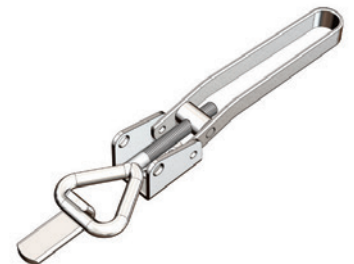
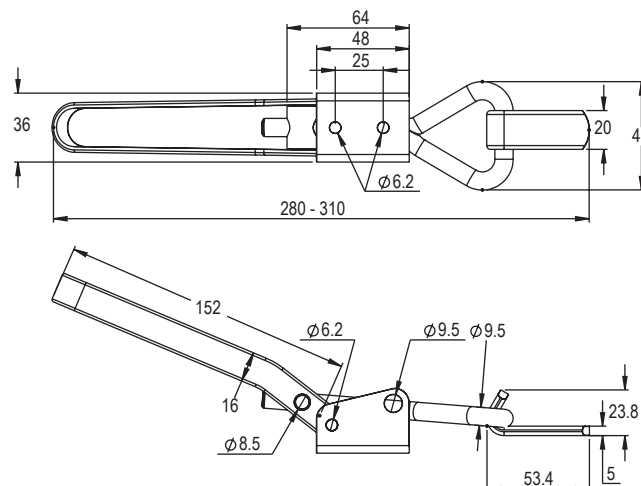

Weld On Over Centre Fastener OF0057ZP

MATERIAL

Steel

FINISH

ZP

WEIGHT

774g

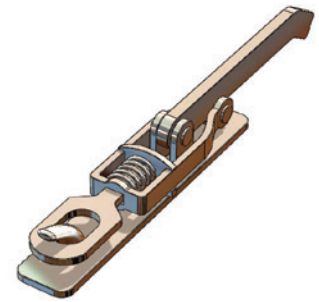
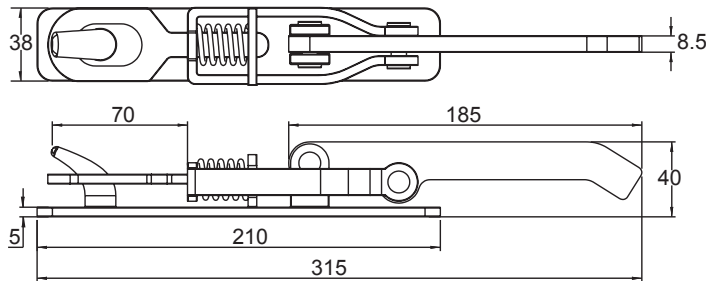

Draw Latches OF91LSS, OF91LCSS

MATERIAL

Stainless Steel

FINISH

Raw

FEATURES

Adjustable grip, kick-out feature disengages from keeper.
Secondary catch option prevents accidental opening.

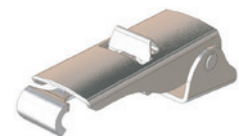
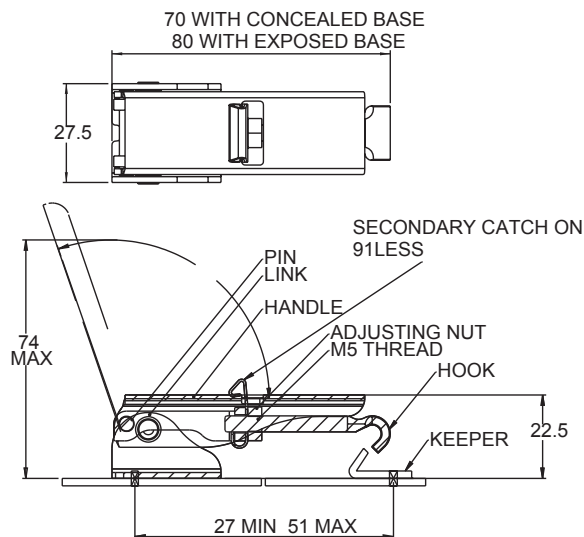

OF91LSS:
Exposed base with secondary catch



OF91LCSS:
Concealed base with secondary catch



Trade Stand Available Now!
Call us on 1300 00 1904
for further information



Over Centre Fastener W/ Catch Plate

OF613ZP, OF613SS

MATERIAL

OF613ZP - Mild Steel
OF613SS - Stainless Steel

FINISH

OF613ZP - ZP
OF613SS - Polished

WEIGHT

OF613ZP - 29.5g
OF613SS - 24g

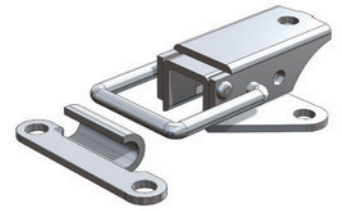
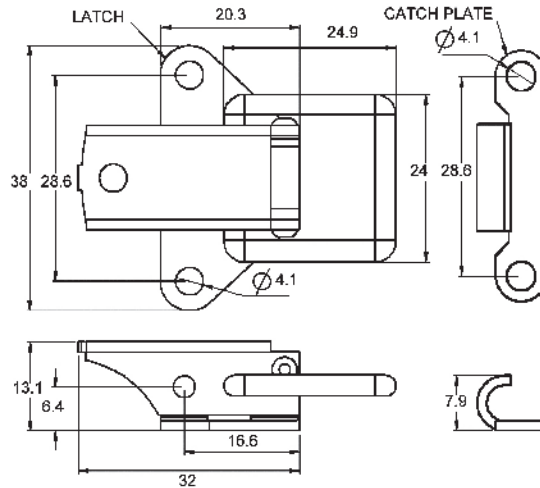

Over Centre Fastener W/ Catch Plate

OF569ZP, OF569SS

MATERIAL

OF569ZP - Mild Steel
OF569SS - Stainless Steel

FINISH

OF569ZP - ZP
OF569SS - Polished

WEIGHT

OF569ZP - 29g
OF569SS - 36.5g

FEATURES

Padlockable.
OF569ZP includes catch-plate 01-507MS.
OF569SS includes catch-plate 01-535SS.

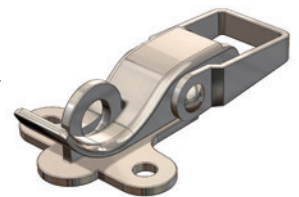
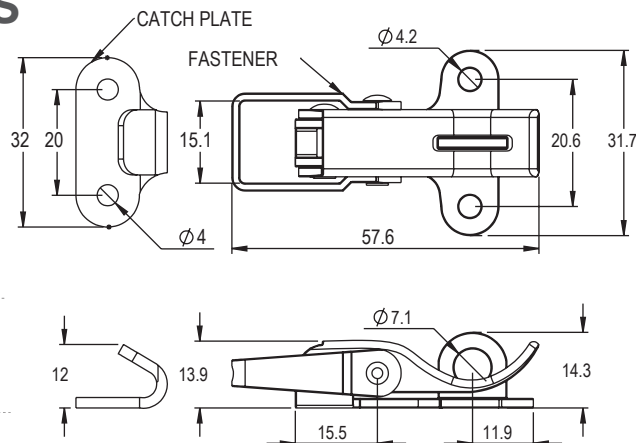

Over-Centre Fastener W/ Catch Plate

OF-570ZP, OF-570SS

MATERIAL

OF-570ZP - Mild Steel
OF-570SS - Stainless Steel

FINISH

OF-570ZP - ZP
OF-570SS - Polished

WEIGHT

OF-570ZP - 114g
OF-570SS - 115g

FEATURES

OF-570MS includes catch-plate 05-502MS.
OF-570SS includes catch-plate 05-502SS.

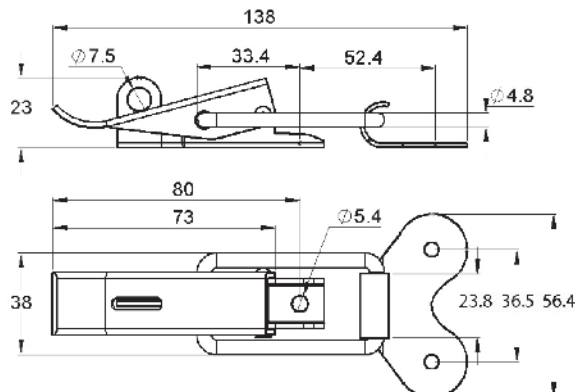

Over Centre Fastener OF3590LZP

MATERIAL

Mild Steel

FINISH

ZP

WEIGHT

156g

FEATURES

Key Lockable

Suits Strikers

OF73HKZP-3

OF73HKZP-2

OF73HKZP-1

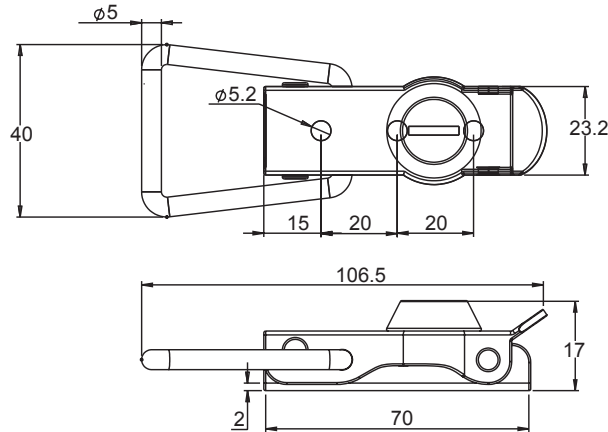

UES
international



Premium Powder Coated Toolbox

Material Steel

- Features**
- 1.5mm thick steel
 - Dust Seal
 - Galvanised
 - Stainless Steel Drop-T Locks
 - Black Powder Coated



Premium Stainless Steel Toolbox

Material Stainless Steel

- Features**
- 1.5mm thick steel
 - High quality Drop-T Handles
 - Adheres to strict welding codes
 - Tested for mechanical resistance & waterproofing



PP Toolbox E0202

POLYPROPYLENE TOOLBOX
600L x 425H x 460Dmm
FAST MOUNTING

- ✓ LOCKABLE
- ✓ RUBBER SEAL
- ✓ PULL-CUT DRAWER
- ✓ LANYARDS FITTED
- ✓ SYSTEM PREDISPOSED FOR FAST MOUNTING

TEL(AUS): 1300 00 1904

TEL(NZ): +64 (0)9 633 4019

www.uesint.com

info@uesint.com

Sydney • Brisbane • Melbourne • Perth • Adelaide • Darwin • Nowra • Auckland

Toggle Latch with Striker Plate

OF3875NLZP

MATERIAL

Steel

FINISH

Zinc Plated

WEIGHT

Toggle Latch 32g
Striker Plate 3.5g

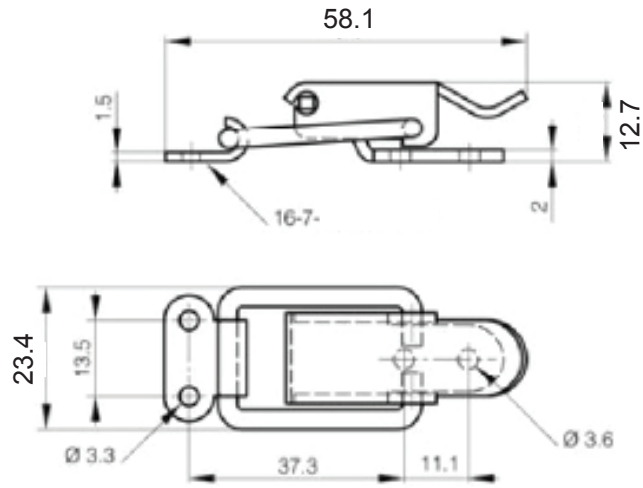

Spring Loaded Stainless Steel Toggle Latch

OF3906NLSS

MATERIAL

304 Stainless Steel

FINISH

Raw

FEATURES

Padlockable

WEIGHT

Toggle Latch 9g
Striker Plate 4.5g

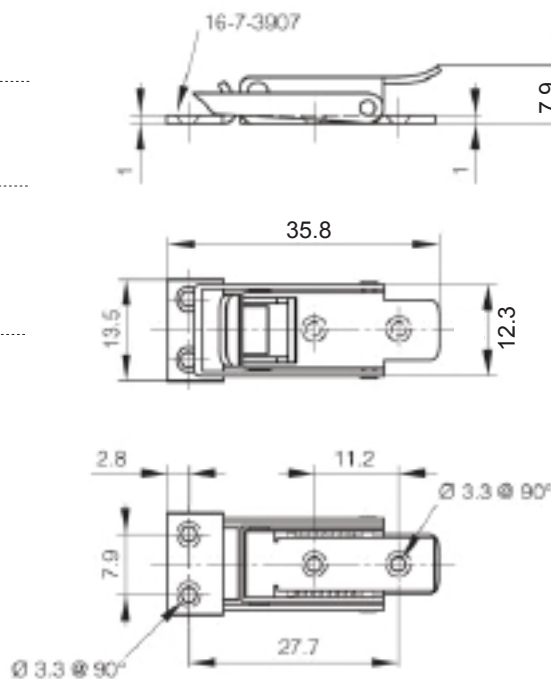

Over Centre Fastener With Hook OF2052LZP

MATERIAL

Mild Steel, Cast

FINISH

Zinc Plated

FEATURES

With hook

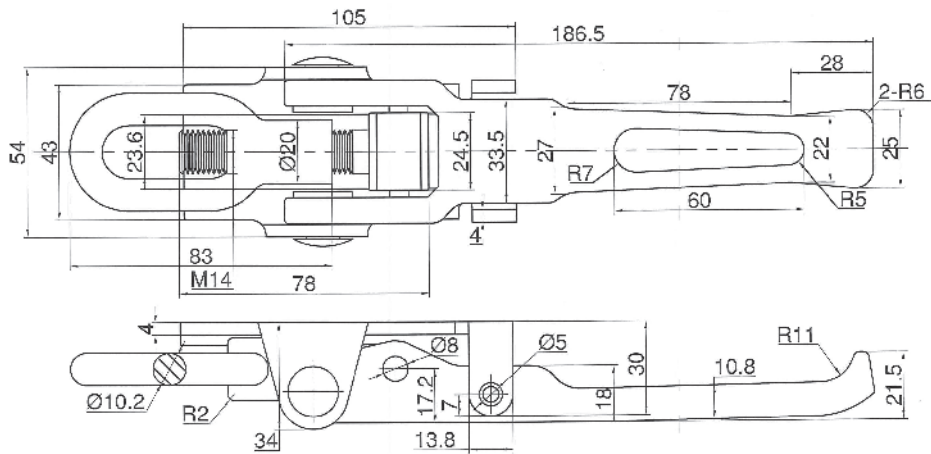

Over Centre Fastener with Hook OF2053LZP

MATERIAL

Mild Steel, Cast

FINISH

Zinc Plated

FEATURES

With hook

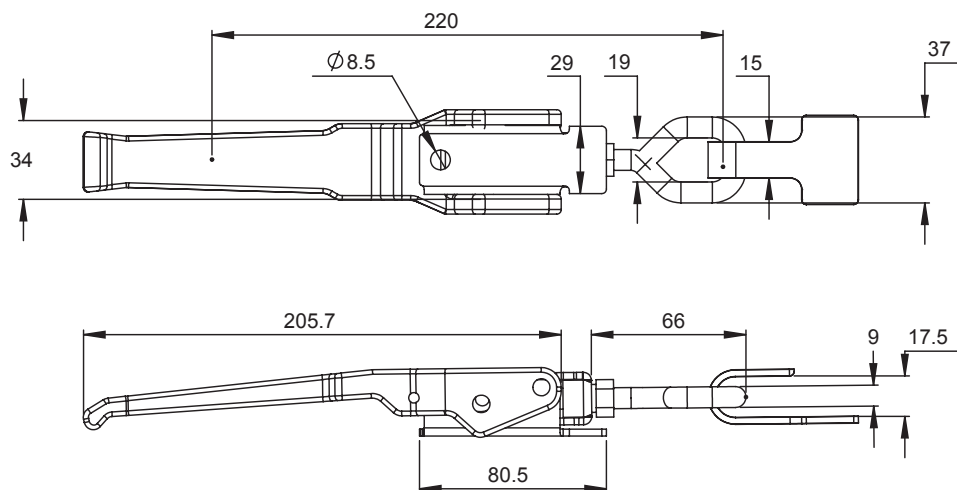
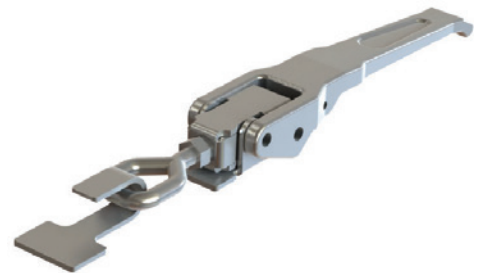

Stainless Steel Push Barrel Bolt

1619008

MATERIAL

Stainless Steel
Steel Shaft
Plastic Button

FINISH

Raw

FEATURES

Spring loaded locking
Weight: 44g

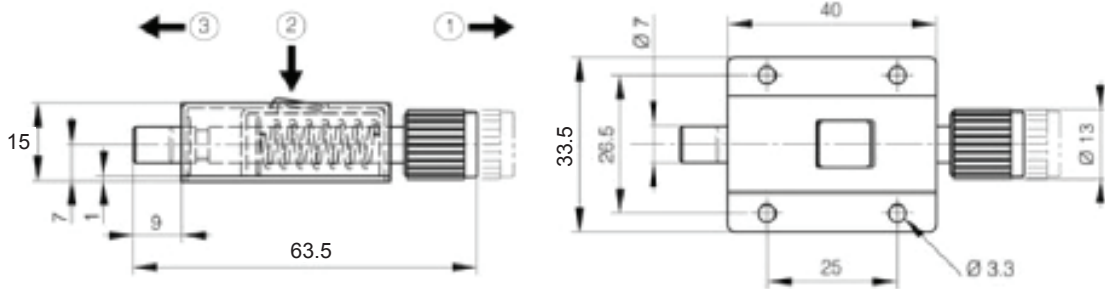
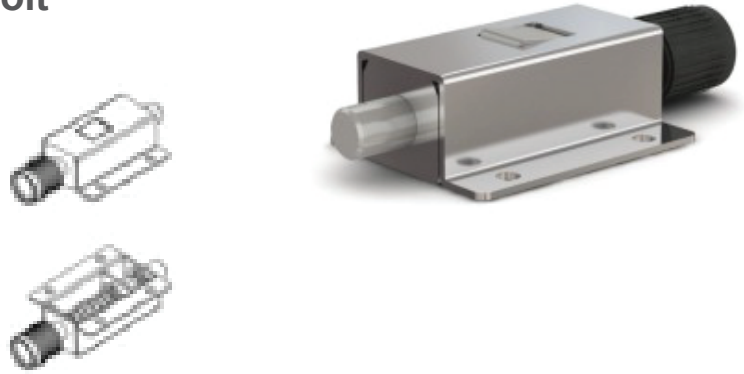

Multi-Functional Spring Bolt

SB05ZPRH, SB05ZPLH, SB05SSRH, SB05SSLH

MATERIAL

Refer to table

FINISH

Refer to table

WEIGHT

Refer to table

	Material	Finish	Weight	RH/LH
SB05ZPRH	Steel	ZP	38.5g	RH
SB05ZPLH	Steel	ZP	38.5g	LH
SB05SSRH	S/Steel 304	Raw	38.5g	RH
SB05SSLH	S/Steel 304	Raw	38.5g	LH



Left Hand product shown

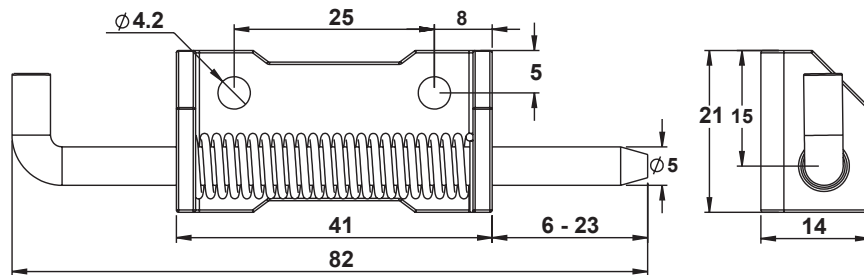

Spring Bolt 12mm Dia Bolt SB12ZPB, SB12SSB

MATERIAL

SB12ZPB Steel
SB12SSB Stainless Steel 316

FINISH

SB12ZPB ZP
SB12SSB Unpolished

WEIGHT

360g

FEATURES

Base Retaining

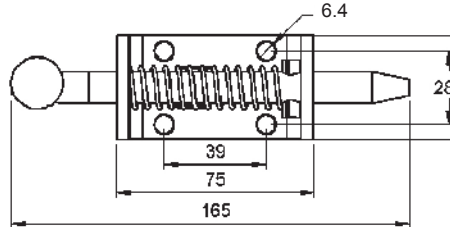
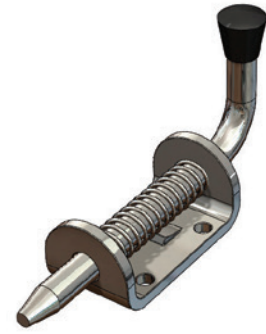
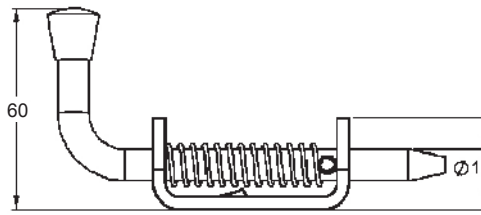

Spring Bolt Cover SBCOVER-BLK, SBCOVER-RED

MATERIAL

Plasticised PVC, UV stable,
75° shore hardness

FINISH

SBCOVER-BLK - Black
SBCOVER-RED - Red

WEIGHT

22g

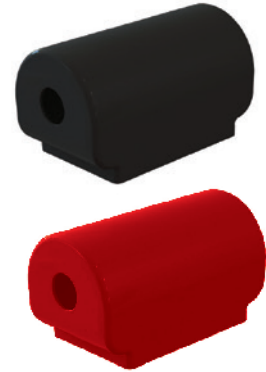
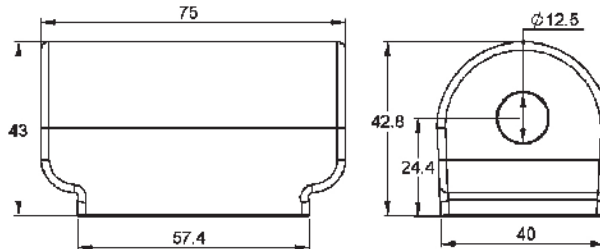

UES
international

Engineering Solutions
Since 1904

The best quality hardware and accessories for your camper trailer, caravan or 4x4 vehicle.

Visit your nearest **UES** showroom or buy online at www.uesint.com

Locks
Hinges
Latches
Rubber & Seals
Gas Struts
Drawer Slides
Water Tanks

UES INTERNATIONAL • UES INTERNATIONAL • UES INTERNATIONAL
ESTD 1904



Sydney, Melbourne, Brisbane, Darwin, Perth, Adelaide, Nowra, Auckland

Spring Bolt, 10mm Dia Bolt SB10ZPP, SB10SSP

MATERIAL

SB10ZPP - Steel
SB10SSP - Stainless Steel 304

FINISH

SB10ZPP - ZP
SB10SSP - Raw

WEIGHT

172g

FEATURES

Pin Retaining

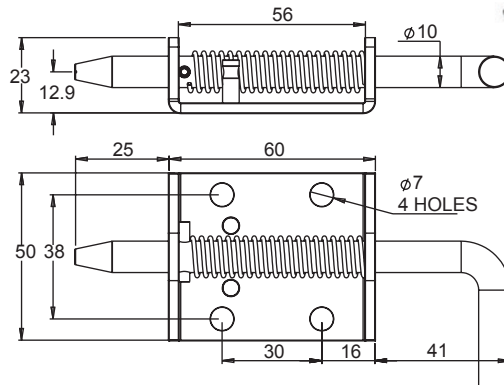

Spring Bolt, 10mm Dia Bolt Long Shoot SP10ZP-LS

MATERIAL

Steel

FINISH

ZP

WEIGHT

216g

FEATURES

Pin Retaining
Long Shoot

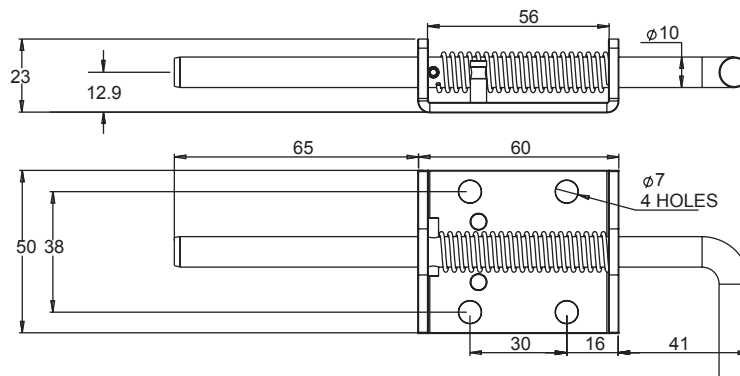

Spring Bolt 13mm Dia Bolt SB13ZPP, SB13ZP-UNASS

MATERIAL

SB13ZPP - Steel
SB13ZP-UNASS - Steel

FINISH

SB13ZPP - ZP
SB13ZP-UNASS - ZP

WEIGHT

360g

FEATURES

Pin Retaining
SB13ZP-UNASS - Unassembled version

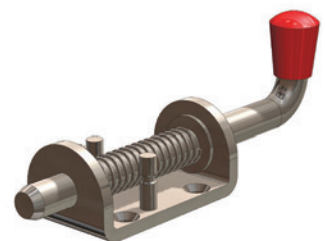
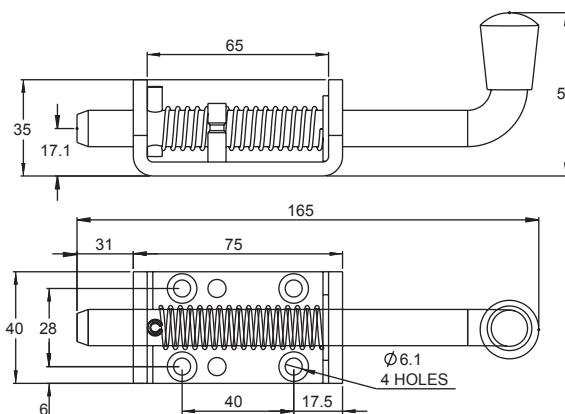

Spring Bolt Ø13 SB13ZPB-XL

MATERIAL

Mild Steel

FINISH

ZP

FEATURES

Base Retaining

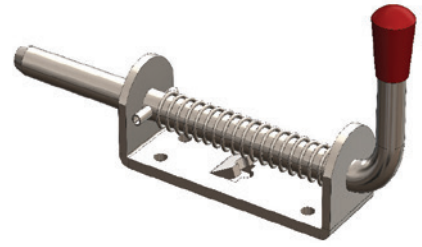
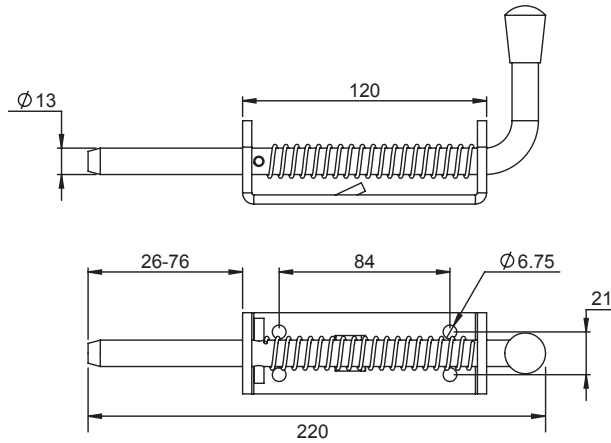

Spring Bolt Padlockable Ø13 SB13ZP-L

MATERIAL

Mild Steel

FINISH

ZP

FEATURES

Suits 8mm padlock
Pin retaining

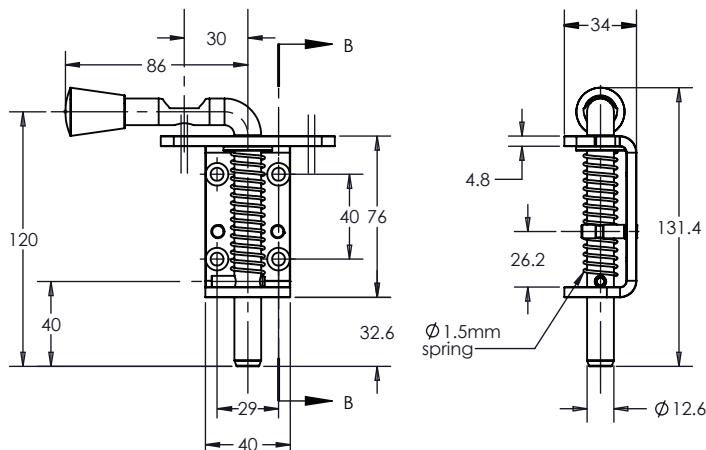

Spring Bolt, 16mm Dia Bolt SB16ZPB

MATERIAL

Steel

FINISH

ZP

WEIGHT

550g

FEATURES

Base Retaining

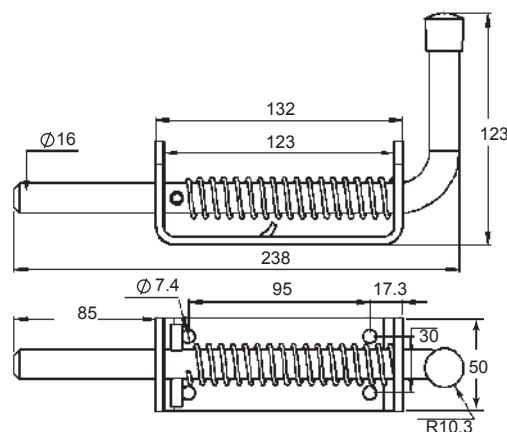

Baby Antiluce Fastener Weld On

AFW08ZP

MATERIAL

Steel

FINISH

ZP

WEIGHT

30g

FEATURES

A versatile fastener. Designed originally for securing vehicle side and tails boards. Its use has been extended to pallets, transit crates, lockers and a wide variety of machinery etc.

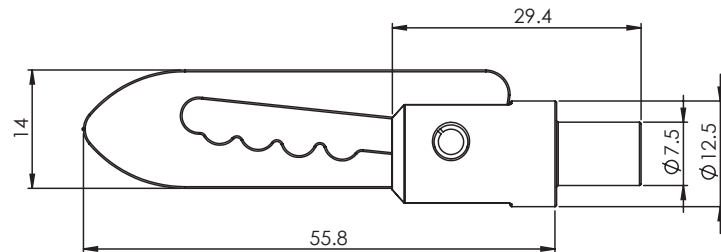

Baby Antiluce Fastener with Nyloc Nut

AFB08SS-20, AFB08SS-40, AFB08ZP-20

MATERIAL

AFB08SS - Stainless Steel 304
AFB08ZP - Steel

FINISH

AFB08SS - Raw
AFB08ZP - ZP

WEIGHT

AFB08SS-20 - 40g
AFB08SS-40 - 42g
AFB08ZP-20 - 40g

DIMENSION (A)

AFB08SS-20 - 20mm
AFB08SS-40 - 40mm
AFB08ZP-20 - 20mm

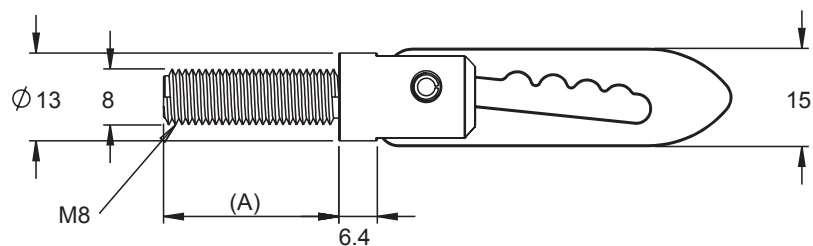

Standard Antiluce Fastener Weld On

AFW12ZP

MATERIAL

Steel

FINISH

ZP

WEIGHT

90g

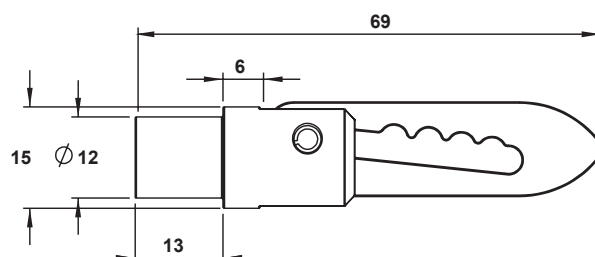
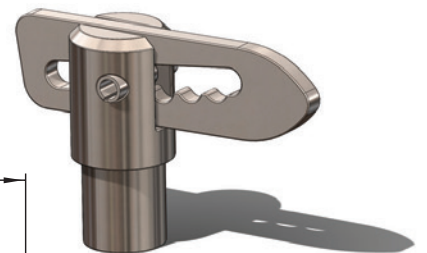

Standard Antiluce Fastener Bolt On AFB12ZP-25, AFB12ZP-50, AFB12SS-50, AFB12ZP-60, AFB12ZP-75

MATERIAL

Steel

FINISH

AFB12ZP-25, AFB12ZP-50,
AFB12ZP-60, AFB12ZP-75: ZP
AFB12SS-50: Stainless Steel

WEIGHT

120g

THREAD LENGTH (A)

AFB12ZP-25: 25mm
AFB12ZP-50: 50mm
AFB12SS-50: 50mm
AFB12ZP-60: 60mm
AFB12ZP-75: 75mm

FEATURES

Nyloc nut supplied

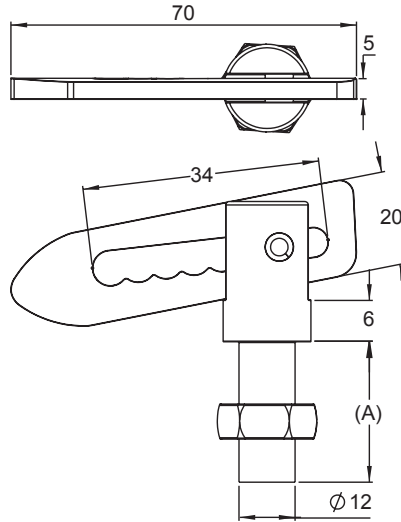

Rubber Buffer AFRB12-3, AFRB12-6

MATERIAL

Rubber

FINISH

Black

FEATURES

AFRB12-3 is 3mm thick
AFRB12-6 is 6mm thick
Suits antiluce fastener

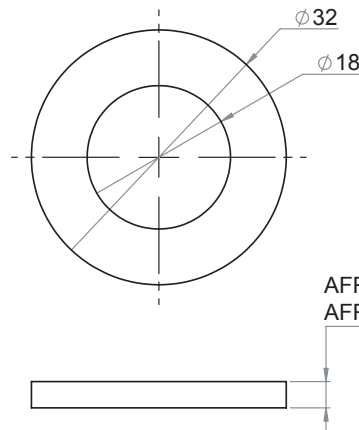

AFRB12-3 is 3mm
AFRB12-6 is 6mm

Catch Plate + Rubber Washer AFRBCP12

MATERIAL

Mild Steel, Rubber

FINISH

Zinc Plated

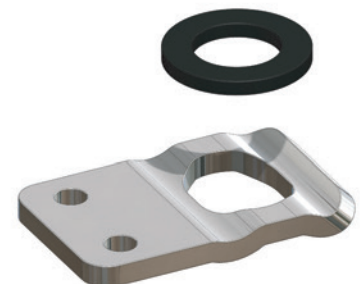
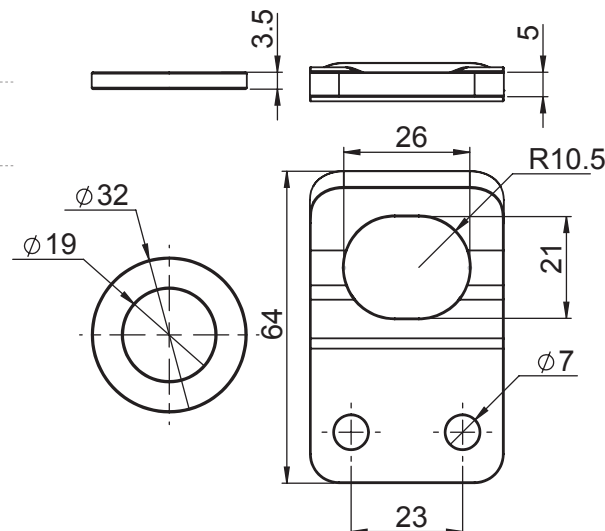

235mm Hasp & Staple G3058PZN

MATERIAL
Steel

FINISH
ZP

WEIGHT
612g

FEATURES
Heavy Duty Brass Pin

PRODUCT DIMENSIONS

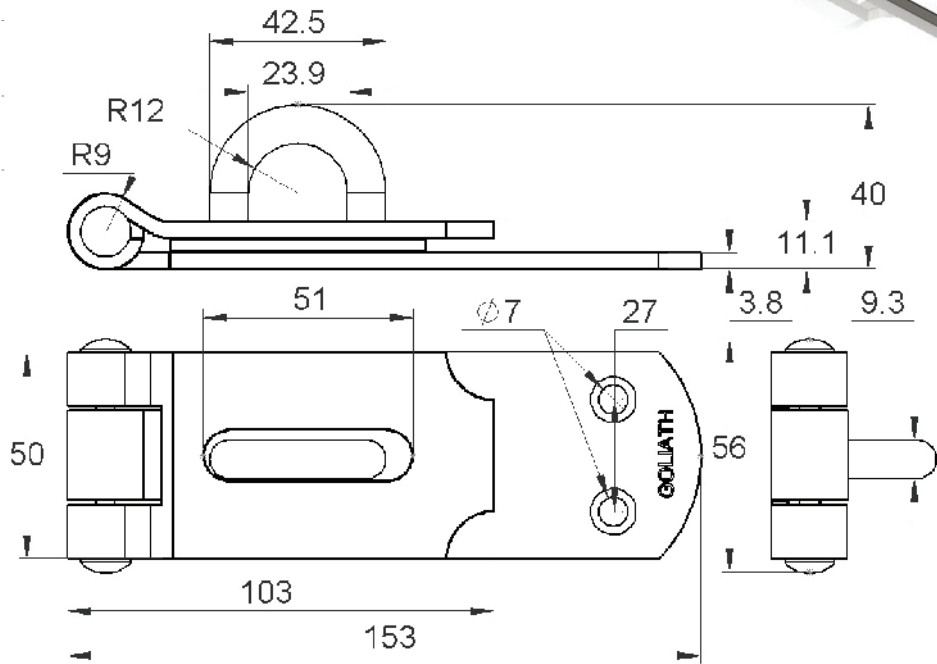

185mm Hasp & Staple HS185ZP

MATERIAL
Steel

FINISH
ZP

WEIGHT
415g

FEATURES
Heavy Duty Brass Pin

PRODUCT DIMENSIONS

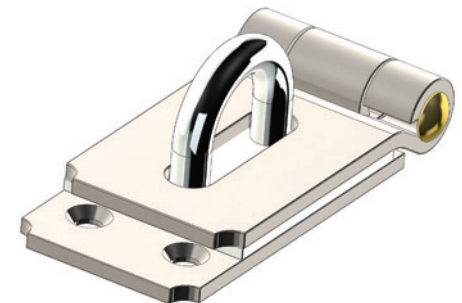
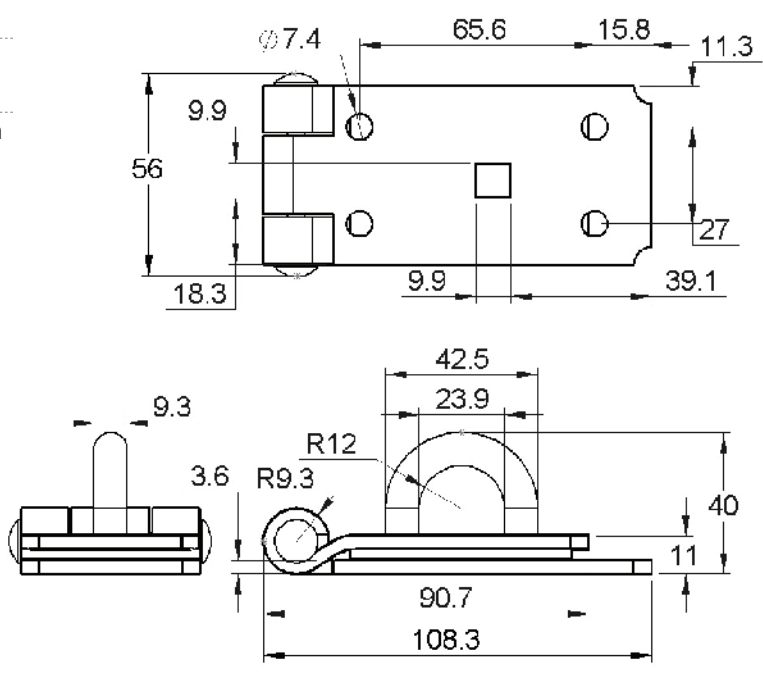

Coil Type Spring CS360ZP

MATERIAL
Steel

FINISH
ZP

WEIGHT
765g

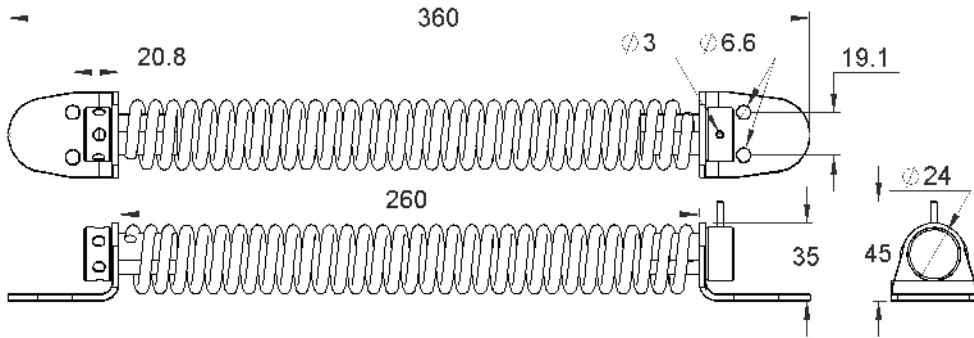

Drop Bolt DB440ZP, DB310ZP

MATERIAL
Steel

FINISH
ZP

WEIGHT
DB440ZP - 505g
DB310ZP - 485g

DIMENSION "A"
DB440ZP - 440mm
DB310ZP - 310mm

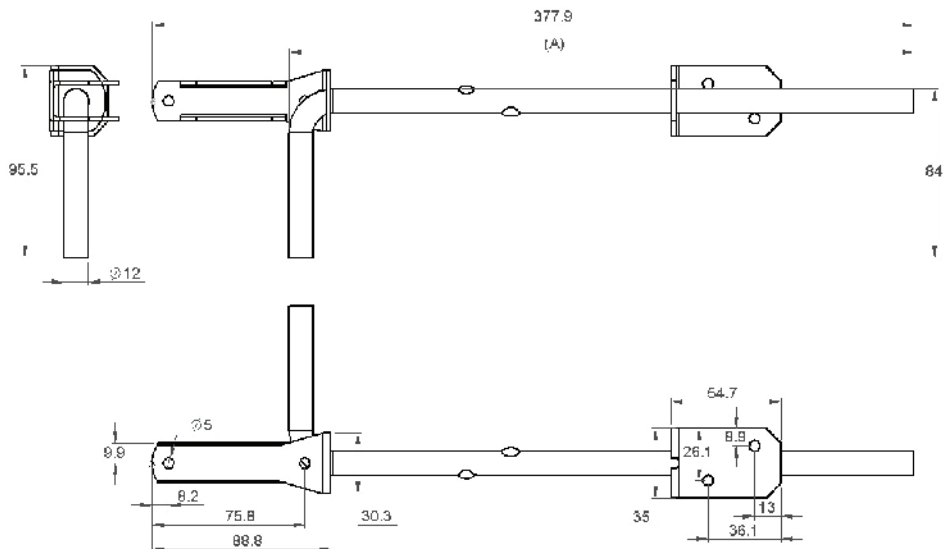

100mm Single Eye, Standard Shoot Padbolt PB100ZP, PB100SS

MATERIAL

Steel

FINISH

PB100ZP - Zinc Plated

PB100SS - Stainless Steel

WEIGHT

133g

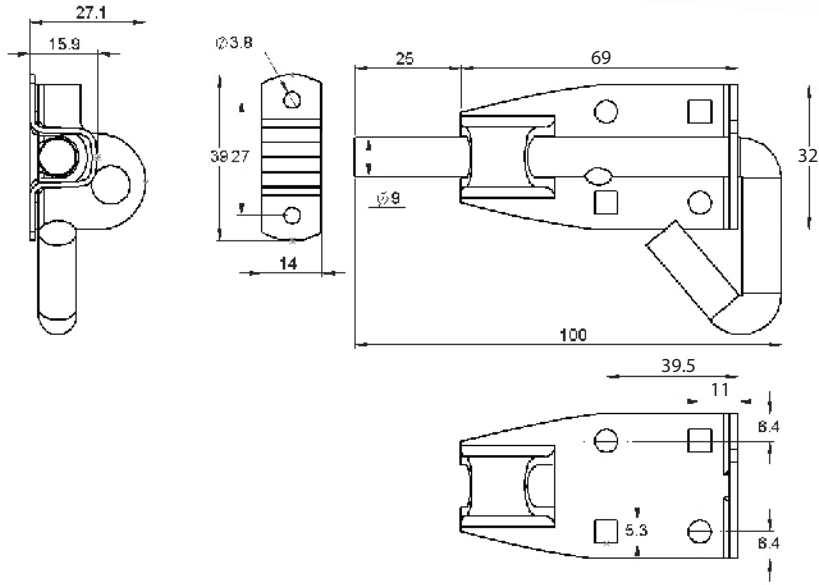

120mm Single Eye, Long Shoot Padbolt PB120ZP

MATERIAL

Steel

FINISH

ZP

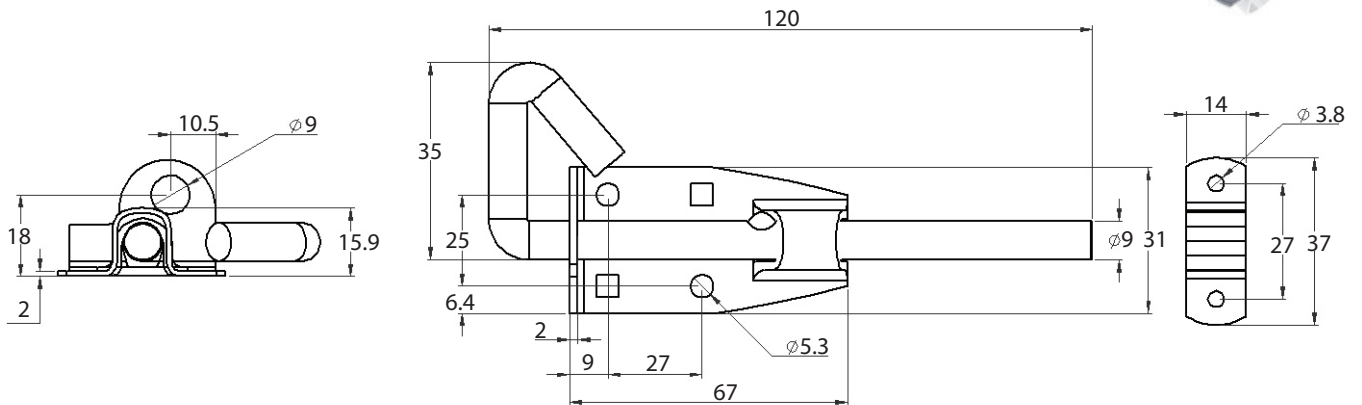

Pad Bolt

PB150ZP, PB170ZP

MATERIAL

Steel

FINISH

ZP

WEIGHT

PB150ZP - 344g

PB170ZP - 357g

DIMENSION "A"

PB150ZP - 40mm

PB170ZP - 60mm

DIMENSION "B"

PB150ZP - 150mm

PB170ZP - 170mm

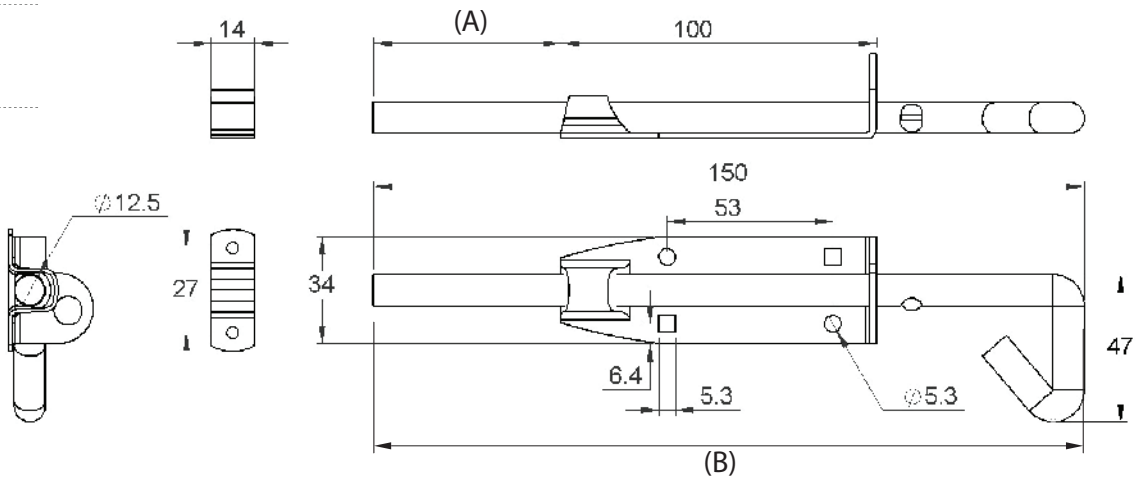
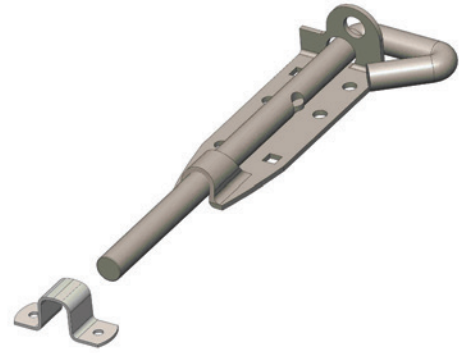



UES
international
Engineering Solutions Since 1904

Equip your Truck with the Best

Premium Toolboxes and Access Ladders for all Vehicles



Stainless Steel or Powdercoated. Thicker sheet metal, robotically welded and designed to endure the toughest conditions.
Quality you can count on from UES

TEL(AUS): 1300 00 1904 TEL(NZ): +64 (0)9 633 4019 www.uesint.com info@uesint.com

Showrooms in Sydney • Brisbane • Melbourne • Perth • Adelaide • Darwin • Nowra • Auckland

Rubber Hood Fastener RBF27ZP, RBF27SS

MATERIAL

RBF27ZP - Rubber / Steel

RBF27SS - Rubber/Stainless Steel

FINISH

RBF27ZP - ZP bracket

RBF27SS - Polished/Stainless Steel bracket

WEIGHT

100g

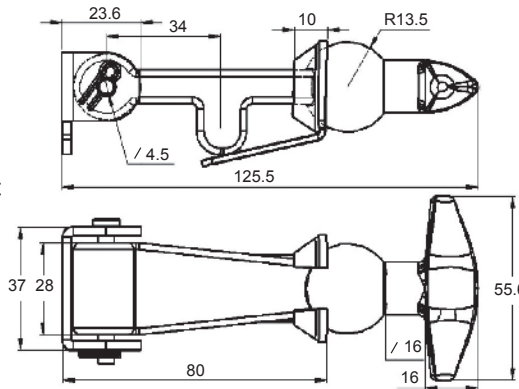

Rubber Hood Fastener 202mm RBF112ZP

MATERIAL

Rubber / Steel

FINISH

ZP bracket

WEIGHT

200g

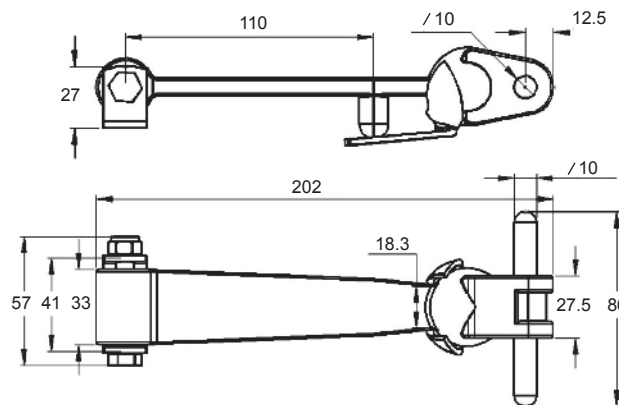

Rubber Bonnet Catch RBF602ZP

MATERIAL

Rubber / Steel

FINISH

Chromatised ZP bracket

WEIGHT

50g

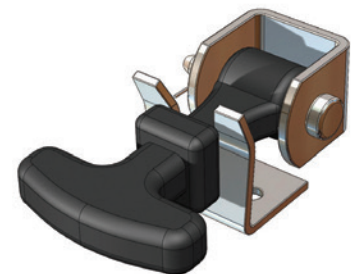
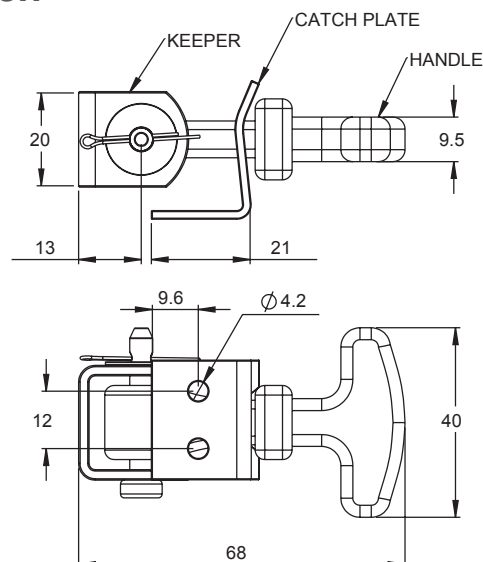

Flexible T-Handle Latch

RBF7

MATERIAL

Keeper- Nylon
 Handle - Rubber
 Bracket - Nylon

FINISH

Black

DESIGN

Contains both front & concealed fixing brackets & keepers.

FEATURES

Flexible handle latch.
 Latch handle remains stationary when unlatched.
 Non-corrosive materials.

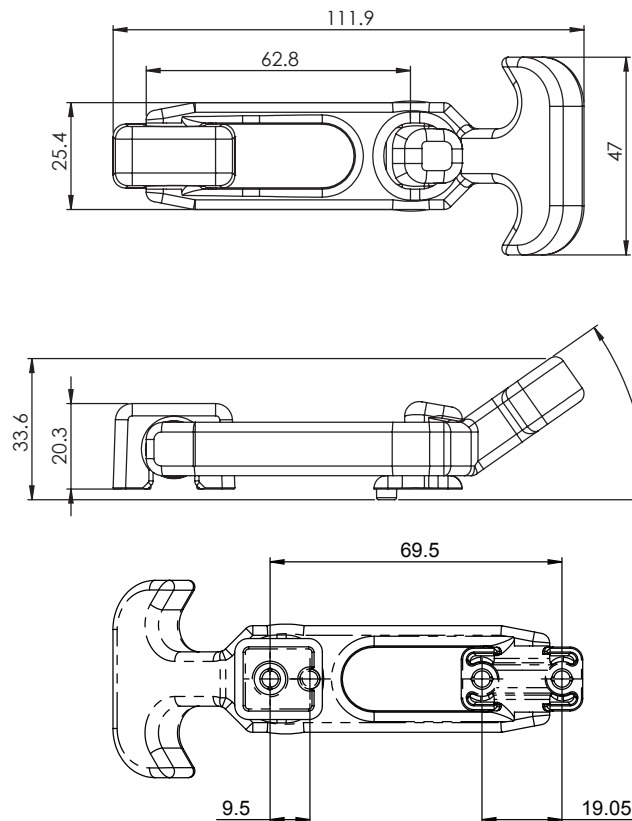

Nylon Door Catches

DH46PL, DH46PL-F, DH46PL-M

MATERIAL

Nylon

FINISH

White

WEIGHT

DH46PL - 40g
 DH46PL-F - 20g
 DH46PL-M - 20g

PARTS

DH46PL kit:

DH46PL-F - Female part only
 DH46PL-M - Male part only

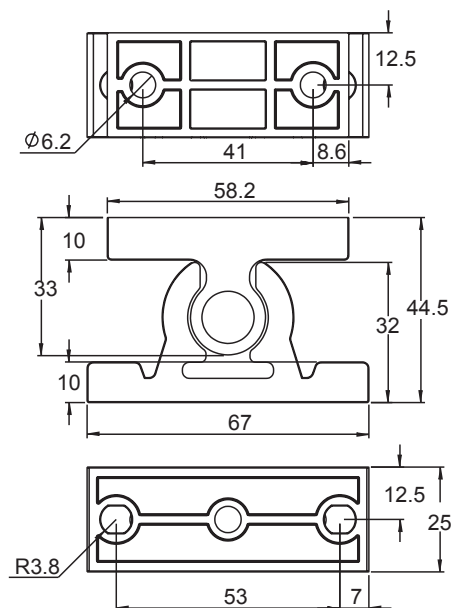

DH46PL kit:

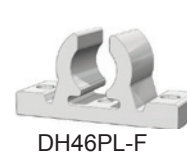
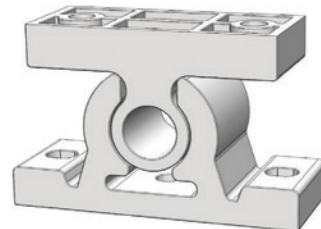

DH46PL-F

DH46PL-M

Door Hold Catch DH32ZP

MATERIAL

Malleable Iron - Cast Steel
S/S Springs

FINISH

ZP

WEIGHT

250g

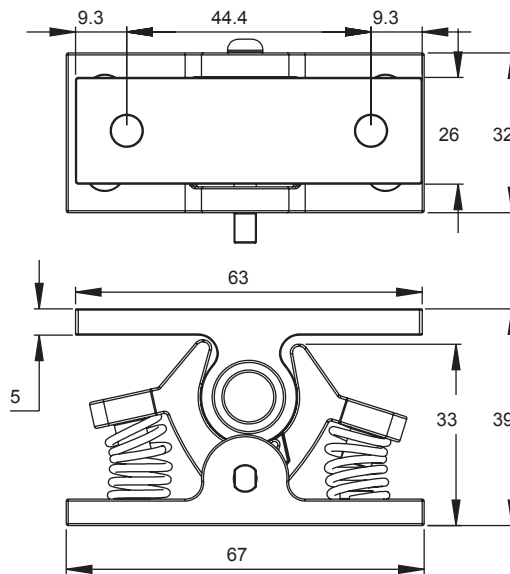

Door Hold Catch DH32ZP-1

MATERIAL

Die Cast S/S Springs

FINISH

ZP

WEIGHT

190g

FEATURES

Softer Spring Tension
than DH32ZP

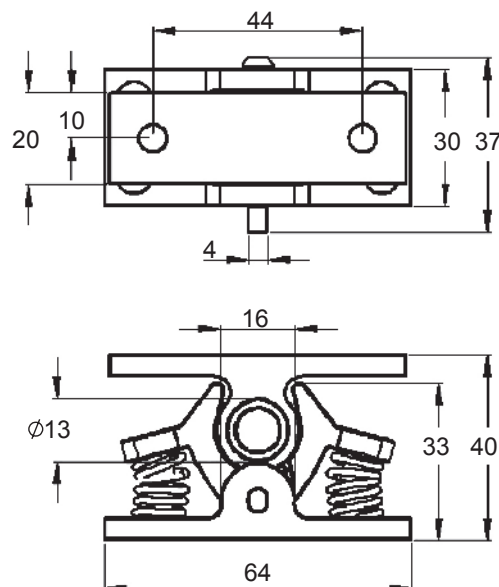

Door Retainer Pin DH603CP-M

MATERIAL

Aluminium, Steel

FINISH

Polished, CP

WEIGHT

20g

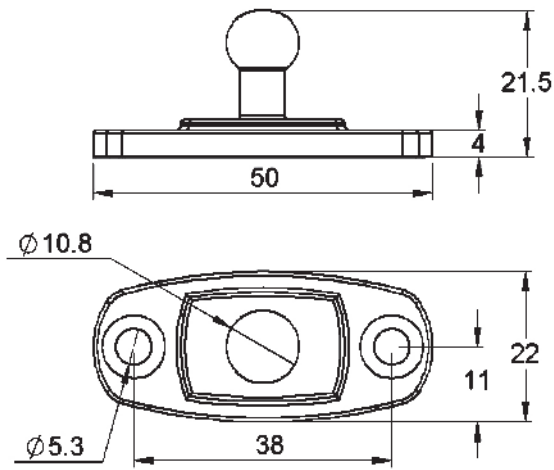

Door Retainer Rubber DH603CP-RB

MATERIAL

Rubber

FINISH

Black

WEIGHT

8g

FEATURES

Self-greasing black rubber

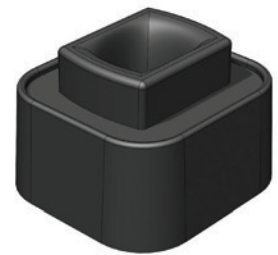
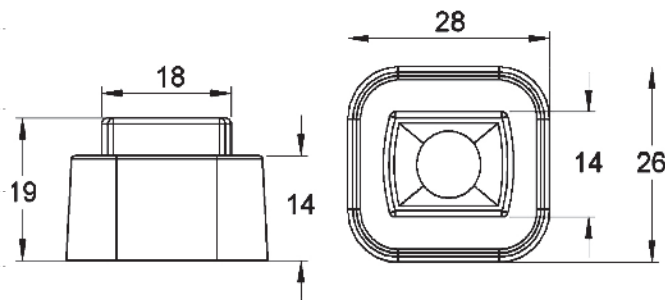

Door Retainer DH603CP-F

MATERIAL

Aluminium/Steel

FINISH

Polished/ CP

WEIGHT

28g

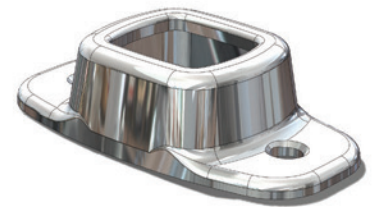
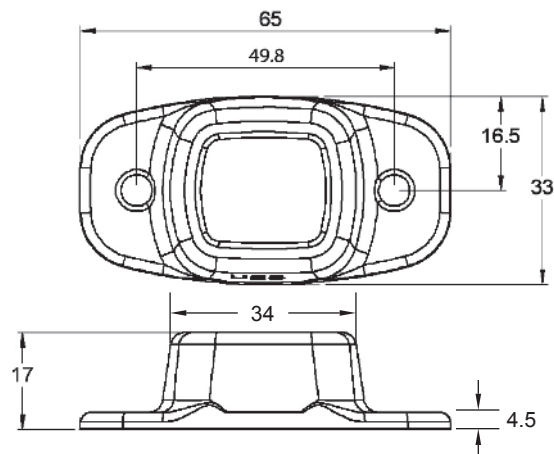

Rubber Door Holder

DH66RB-F, DH66PL-M, DH76RB-F, DH77RB-F, DH78RB-F

MATERIAL

DH66RB-F, DH76RB-F, DH77RB-F, DH78RB-F:
SBR (Styrene-butadiene rubber)
 DH66PL-M: *Polypropylene*

FINISH

DH66RB-F, DH66PL-M, DH77RB-F: *Black*
 DH76RB-F, DH78RB-F: *Blue*

WEIGHT

DH66PL-M: *6g*
 DH76RB-F: *33g*
 DH66RB-F, DH77RB-F, DH78RB-F: *37g*

FEATURES

- DH66RB-F - Female only, minimum load 20kg.
 Typical load 25kg.
- DH66PL-M - Male only (common to all).
- DH76RB-F - Female only, minimum load 3kg.
 Typical load 8kg.
- DH77RB-F - Female only, fixing plate tapped M6, 3mm shorter
- DH78RB-F - Female only, fixing plate tapped M6, 3mm shorter

Male portion

Moulded with a recessed hexagon to take M6 bolt

Female portion

Moulded steel fixing base plate
 A 6mm clearance hole is provided for fixing.
 (Suitable for use in temperatures down to -30° C)



Male part

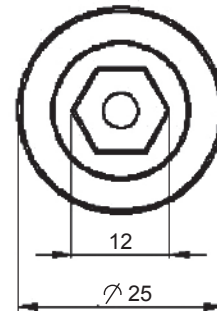
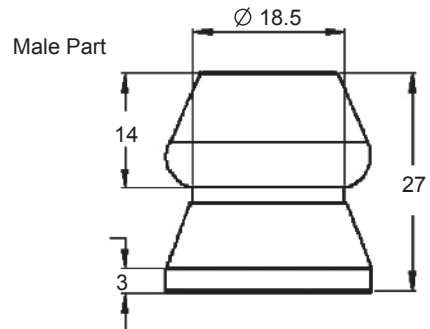
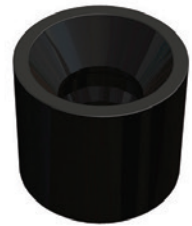

Female Part

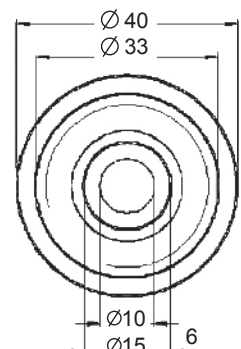
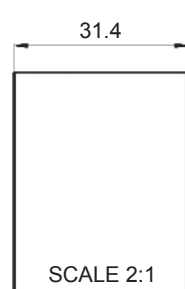

Door Retainer Hook DH50ZP-M

MATERIAL

Malleable Iron

FINISH

ZP

WEIGHT

160g

FEATURES

Cast malleable iron hook with pressed steel back-plate.

DIMENSION (A)

101mm

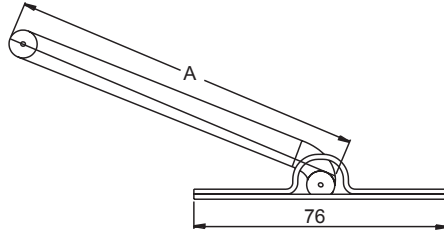
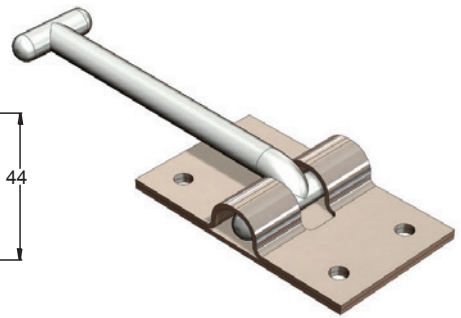
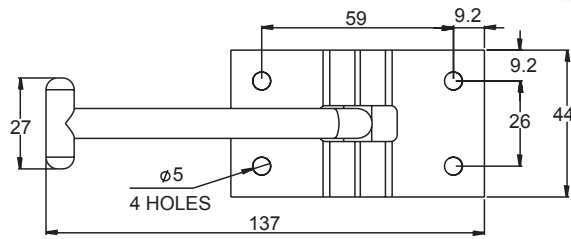

Door Retainer Catch DH50ZP-F

MATERIAL

Pressed Steel

FINISH

ZP

WEIGHT

80g

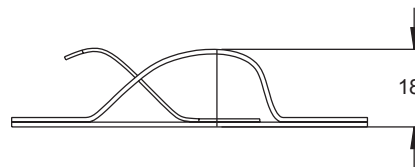
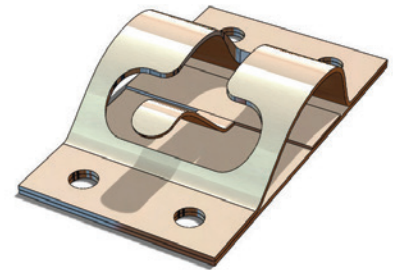
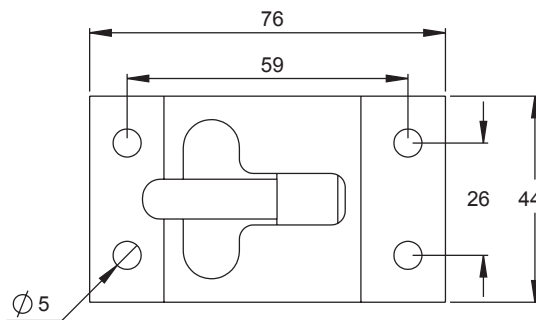

Door Holder DH35SS-M

MATERIAL

Stainless Steel

FINISH

Polished

WEIGHT

60g

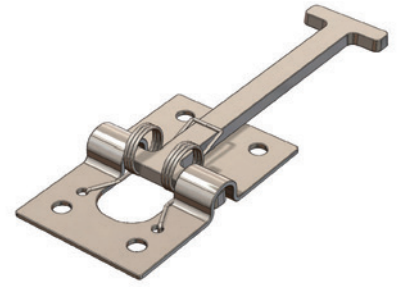
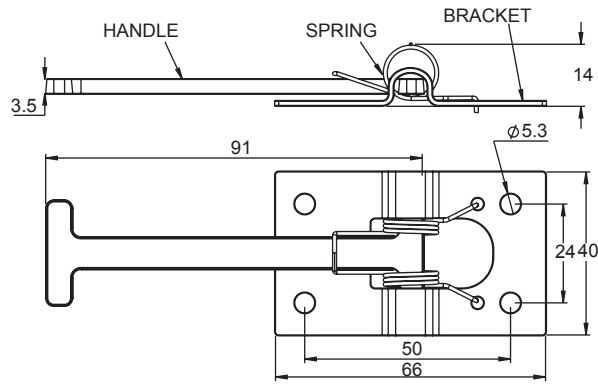

Door Retainer DH35SS-F

MATERIAL

Stainless Steel

FINISH

Polished

WEIGHT

30g

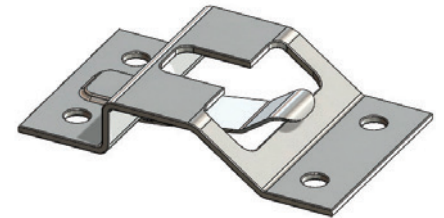
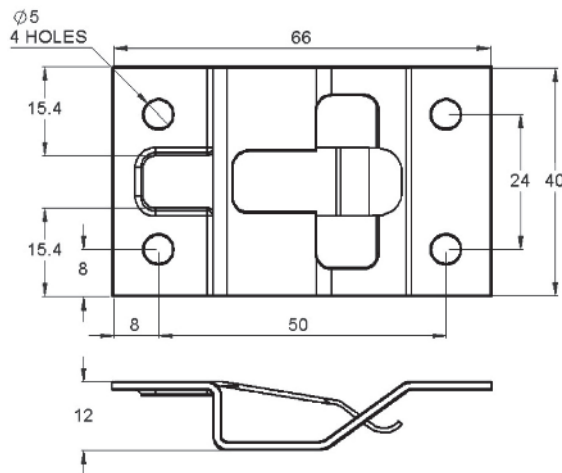

Door Retainer Back Plate DH35PL-BP

MATERIAL

UV Stable Elastomer

FINISH

Black

WEIGHT

12g

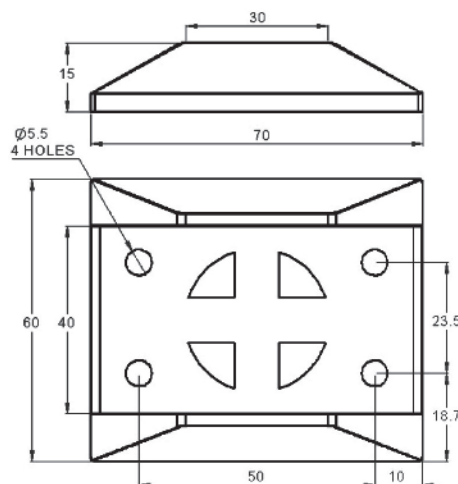

Door Retainer - Stainless Steel

DH59SS

MATERIAL

Stainless Steel/Plastic

FINISH

Polished

WEIGHT

102g

FEATURES

Door retainer set containing hook assembly, catch plate and plastic back plates

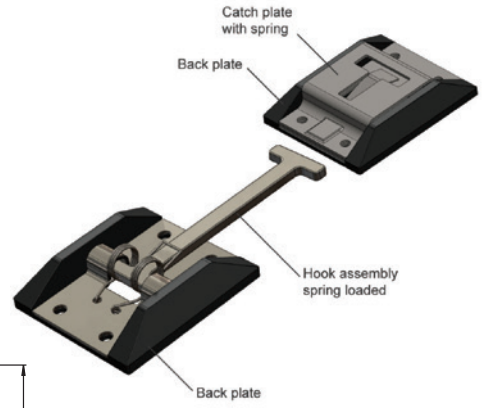
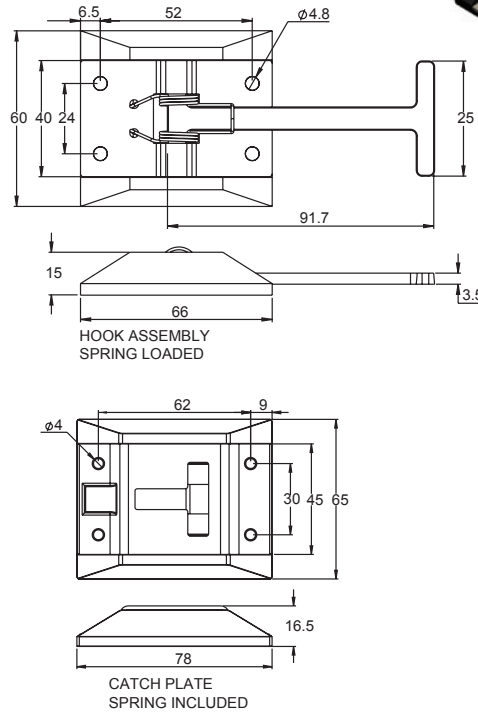

Door Retainer Set

DH36SS

MATERIAL

Stainless Steel

FINISH

Polished

WEIGHT

90g

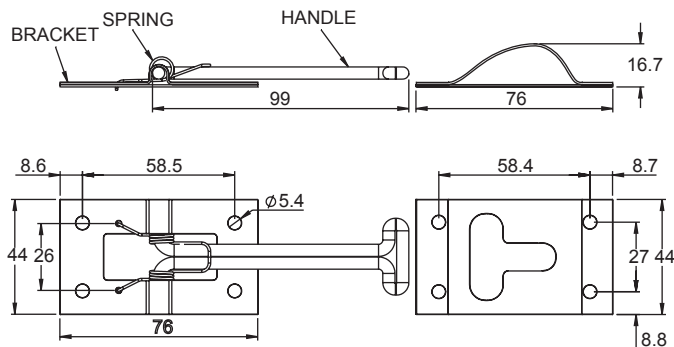
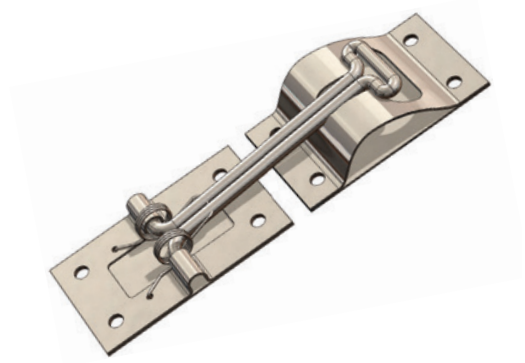

Floor Trap Fastener

2171-002, 2171-305, 2172-002

MATERIAL

Steel

FINISH

ZP

WEIGHT

- 2171-002 - 200g
- 2171-305 - 105g
- 2172-002 - 200g

FEATURES

2171-002
Slotted round head male and female assembly
12mm thread.

2171-305
Female bracket and nut only
12mm thread

2172-002
Slotted round head male and female assembly.
Acme thread (coarse).

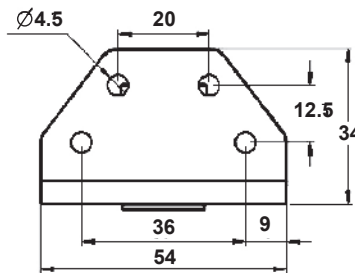
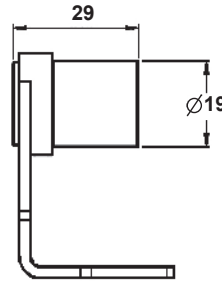
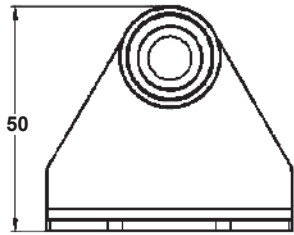
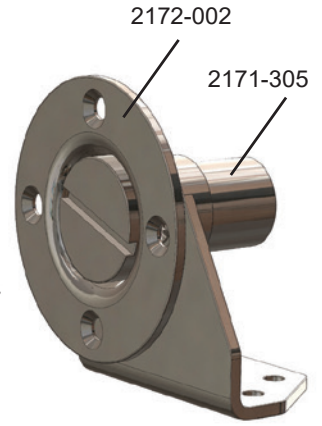
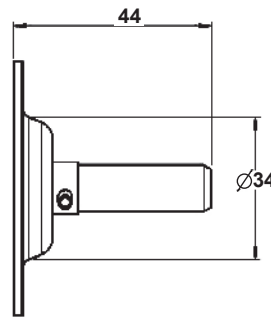
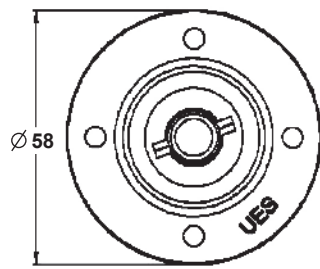

Grip Clips

RP02ZP, RP02-5ZP, RP03ZP, RP04ZP, RP05ZP, RP06ZP, RP07ZP

MATERIAL

Steel

FINISH

ZP

SIZES AND WEIGHTS

Please see table below

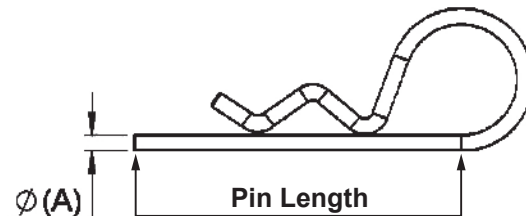

Product Code	Pin Diameter (A)	Suiting Shaft	Weight	Pin Length
RP02ZP	2mm	6-11mm	5g	35mm
RP02-5ZP	2.5mm	8-11mm	8g	28mm
RP03ZP	3mm	10-12mm	10g	60mm
RP04ZP	4mm	12-22mm	20g	65mm
RP05ZP	5mm	16-27mm	30g	90mm
RP06ZP	6mm	9-32mm	60g	110mm
RP07ZP	7mm	24-38mm	110g	150mm

Lynch Pins

LP06ZP, LP08ZP, LP04-5ZP, LP09-5ZP, LP11ZP

MATERIAL

Steel

FINISH

ZP

SIZES AND WEIGHTS

Please see table below

Product Number	Diameter (A)	Weight	Diameter of Ring
LP06ZP	4.5mm	11g	36mm
LP08ZP	6mm	20g	39mm
LP04-5ZP	8mm	30g	38mm
LP09-5ZP	9.5mm	40g	37mm
LP11ZP	11mm	50g	40mm

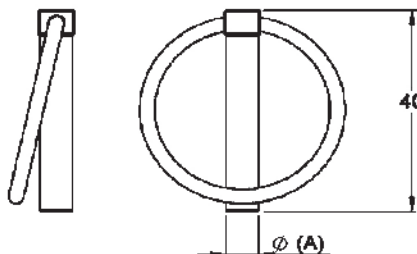

Shaft Locking Pins

SLP06ZP, SLP08ZP, SLP9-5ZP, SLP11ZP

MATERIAL

Steel

FINISH

ZP

SIZES

Please see table below

Part Number	Diameter	Length (B)	Height (C)
SLP06ZP	6mm	50mm	38mm
SLP08ZP	8mm	57mm	35mm
SLP9-5ZP	9.5mm	57mm	38mm
SLP11ZP	11mm	89mm	54mm

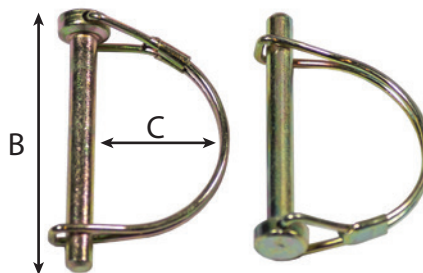

UES
international



Side Underrun Protective Devices
Ph(AUS): **1300 00 1904**
www.uesint.com

Magnetic Catch 4kg Force

MC04NP

MATERIAL

Zinc Die Cast

FINISH

Nickel Plated

WEIGHT

43g

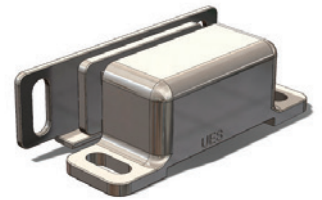
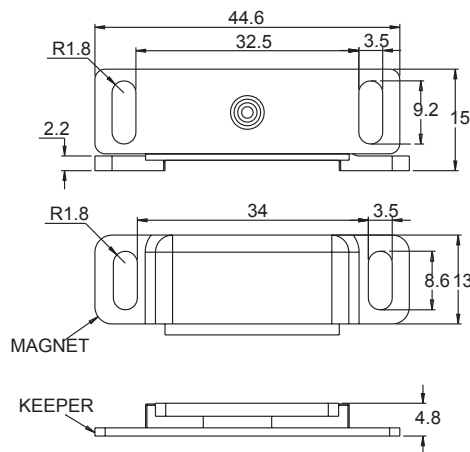
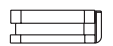
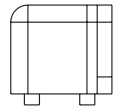

Magnetic Catch 8kg Force

MC08NP

MATERIAL

Zinc Die Cast

FINISH

Nickel Plated

WEIGHT

70g

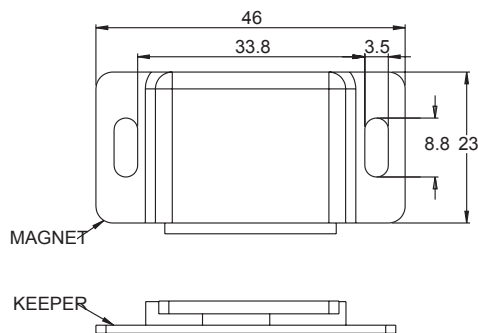

Magnetic Catch 11kg Force

MC11NP

MATERIAL

Zinc Die Cast

FINISH

Nickel Plated

WEIGHT

92g

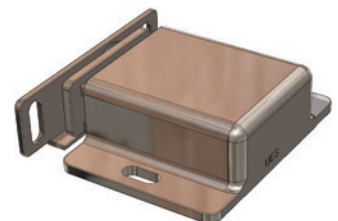
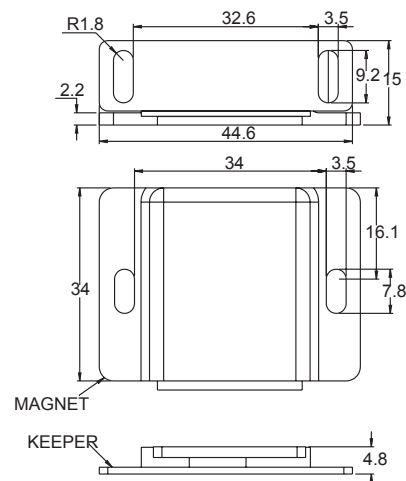
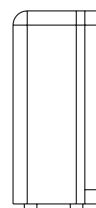

Magnetic Catches 140N MC14SS

MATERIAL

Stainless Steel

FINISH

Mirror

WEIGHT

11g

FEATURES

Suitable for high temperature environments up to 250° C.
Strong magnetic force.

MC14SS : 140N Force

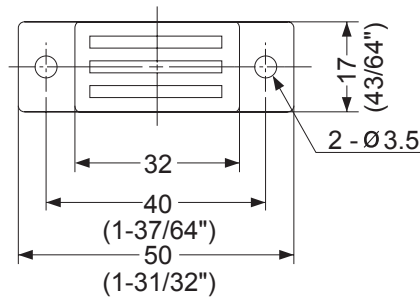
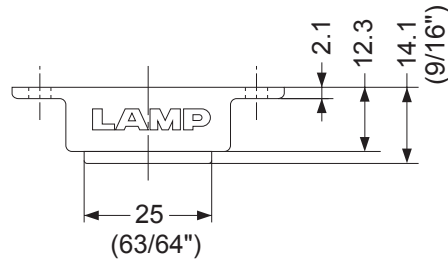

UES
international
Engineering Solutions
Since 1904

High quality gas struts and drawer slides for your camper trailer, caravan or 4x4 vehicle.

Visit your nearest UES showroom or find us at:

(AUS) 1300 00 1904 www.uesint.com

- Locks
- Hinges
- Latches
- Rubber & Seals
- Gas Struts
- Drawer Slides
- Water Tanks



Dovetail Female DV2-F

MATERIAL

AlSiMg Die Cast

FINISH

Mill Finish Aluminium

WEIGHT

66g

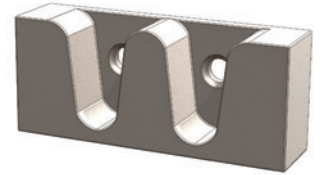
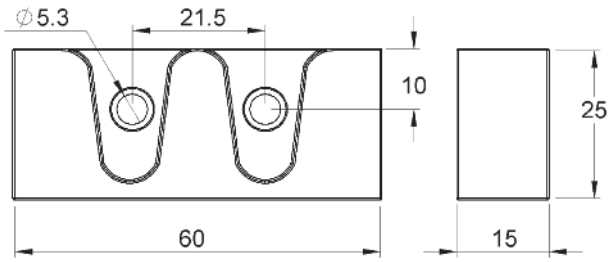

Dovetail Male DV2-M

MATERIAL

AlSiMg Die Cast/Rubber

FINISH

Die-cast aluminium covered with self-greasing black rubber

WEIGHT

34g

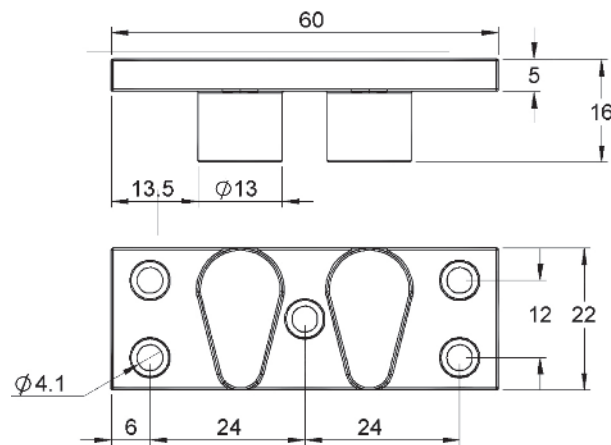

Dovetail Female DV3-F

MATERIAL

AlSiMg Die Cast

FINISH

Mill Finish Aluminium

WEIGHT

122g

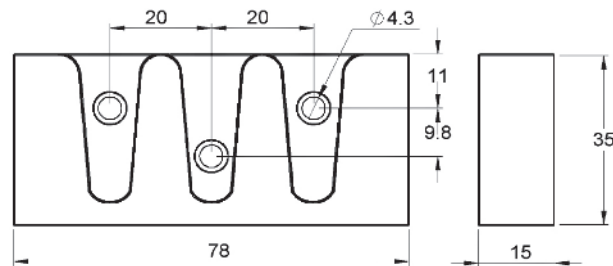

Dovetail Male DV3-M

MATERIAL

AlSiMg Die Cast/Rubber

FINISH

Die-cast aluminium covered with self-greasing black rubber

WEIGHT

61g

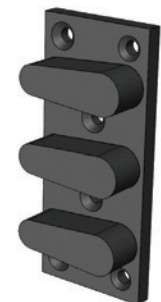
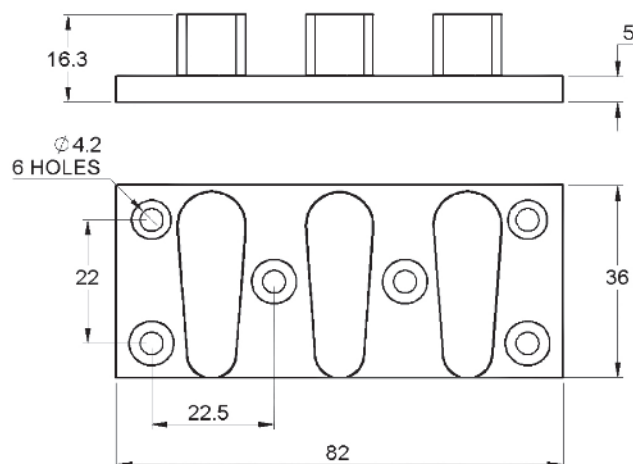

U Bolts

UB10ZP → UBSP-3

MATERIAL

Steel

FINISH

ZP

FEATURES

The following is a popular range, but many other sizes can be made.

Part No.	B x A
UB10ZP	10 x 3 5/8 x 1/2"
UB11ZP	11 x 3 5/8 x 1/2"
UB12ZP	12 x 3 5/8 x 1/2"
UB13ZP	13 x 3 5/8 x 1/2"
UB14ZP	14 x 3 5/8 x 1/2"
UB15ZP	15 x 3 5/8 x 1/2"
UB16ZP	16 x 3 5/8 x 1/2"
UB17ZP	17 x 3 5/8 x 1/2"
UB18ZP	18 x 3 5/8 x 1/2"
UB19ZP	19 x 3 5/8 x 1/2"
UB20ZP	20 x 3 5/8 x 1/2"
UB21ZP	21 x 3 5/8 x 1/2"
UB22ZP	22 x 3 5/8 x 1/2"

Spreaders	
UBSP-1	3 5/8" plate
UBSP-2	4 1/4" plate
UBNUT-1	1/2 nyloc nut
UBNUT-2	5/8 nyloc nut
UBSP-3	5/8" plate

U Bolts (Heavy Duty) B x A - Zinc Plated	
UBHD11ZP	11" x 4 5/8 x 5/8" ZP (4" centres)
UBHD12ZP	12" x 4 5/8 x 5/8" ZP (4" centres)
UBHD13ZP	13" x 4 5/8 x 5/8" ZP (4" centres)
UBHD14ZP	14" x 4 5/8 x 5/8" ZP (4" centres)
UBHD15ZP	15" x 4 5/8 x 5/8" ZP (4" centres)
UBHD16ZP	16" x 4 5/8 x 5/8" ZP (4" centres)
UBHD17ZP	17" x 4 5/8 x 5/8" ZP (4" centres)
UBHD18ZP	18" x 4 5/8 x 5/8" ZP (4" centres)
UBHD20ZP	20" x 4 5/8 x 5/8" ZP (4" centres)

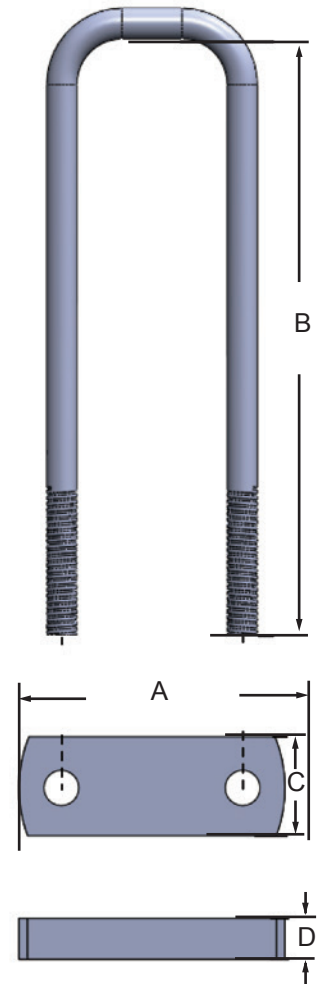



UES
international

Engineering Solutions
Since 1904



Transport Hardware & Rubber

Fasteners, Hinges, Handles, Locks, Gas Struts, Rubber & Seals, Toolboxes & Water tanks,
Steps & Ladders, Side Protection devices, Seating, Ventilation, Accessories.

www.uesint.com Ph(AUS): 1300 00 1904 info@uesint.com

Sydney • Brisbane • Melbourne • Perth • Adelaide • Darwin • Nowra • Auckland